

# *Digital Videocassette Recorder*

---

## **Operating Instructions**

Before operating the unit, please read this manual thoroughly and retain it for future reference.



## **DSR-80/80P**

## Owner's Record

The model and serial numbers are located at the rear. Record the serial number in the space provided below. Refer to these numbers whenever you call upon your Sony dealer regarding this product.

Model No. DSR-80      Serial No. \_\_\_\_\_

### WARNING

**To prevent fire or shock hazard, do not expose the unit to rain or moisture.**

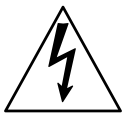
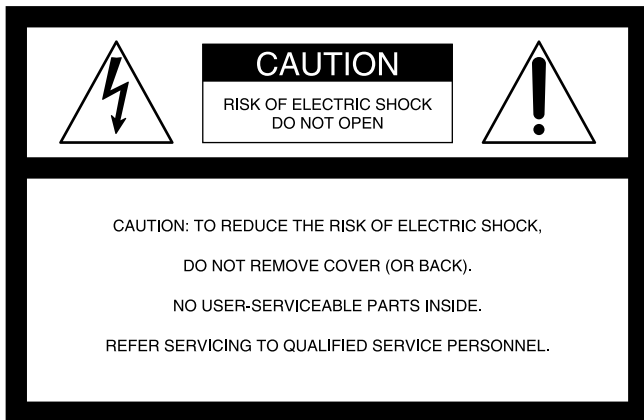

This symbol is intended to alert the user to the presence of uninsulated "dangerous voltage" within the product's enclosure that may be of sufficient magnitude to constitute a risk of electric shock to persons.



This symbol is intended to alert the user to the presence of important operating and maintenance (servicing) instructions in the literature accompanying the appliance.

## For the customers in the USA

This equipment has been tested and found to comply with the limits for a Class A digital device, pursuant to Part 15 of the FCC Rules. These limits are designed to provide reasonable protection against harmful interference when the equipment is operated in a commercial environment. This equipment generates, uses, and can radiate radio frequency energy and, if not installed and used in accordance with the instruction manual, may cause harmful interference to radio communications. Operation of this equipment in a residential area is likely to cause harmful interference in which case the user will be required to correct the interference at his own expense.

You are cautioned that any changes or modifications not expressly approved in this manual could void your authority to operate this equipment.

This device requires shielded interface cables to comply with FCC emission limits.

### Caution

Television programs, films, video tapes and other materials may be copyrighted. Unauthorized recording of such material may be contrary to the provisions of the copyright laws.

## Voor de klanten in Nederland



Bij dit produkt zijn batterijen geleverd. Wanneer deze leeg zijn, moet u ze niet weggooien maar inleveren als KCA.

# Table of Contents

## Chapter 1

### Overview

<b>Features .....</b>	<b>5</b>
<b>Location and Function of Parts .....</b>	<b>8</b>
Front Panel .....	8
Rear Panel .....	14

## Chapter 2

### Recording and Playback

<b>Recording .....</b>	<b>19</b>
Settings for Recording .....	19
Usable Cassettes .....	22
Recording Procedure .....	24
<b>Playback .....</b>	<b>28</b>
Settings for Playback .....	28
Playback Procedure .....	29

## Chapter 3

### Convenient Functions for Editing Operation

<b>Setting the Time Data .....</b>	<b>31</b>
Displaying Time Data and Operation Mode Indications ...	31
Using the Internal Time Code Generator .....	33
Synchronizing Internal and External Time Codes .....	34
Rerecording the Time Code — TC Insert Function .....	35
<b>High-Speed and Low-Speed Search: Quickly and Accurately Determining Editing Points .....</b>	<b>37</b>
Search Operations via External Equipment .....	37
Search Operations on This Unit .....	37
<b>Dubbing Signals in QSDI Format — QSDI Dubbing Function .....</b>	<b>38</b>

# Table of Contents

## Chapter 4

### Menu Settings

<b>Menu Organization .....</b>	<b>41</b>
<b>Menu Contents .....</b>	<b>42</b>
SETUP menu .....	42
<b>Changing Menu Settings .....</b>	<b>51</b>
Buttons Used to Change Settings .....	51
Changing the Settings of Basic Items .....	51
Displaying Enhanced Items .....	53
Changing the Settings of Enhanced Items .....	53
Returning Menu Settings to Their Factory Defaults .....	54
<b>Displaying Supplementary Status Information .....</b>	<b>55</b>

## Chapter 5

### Connections and Settings

<b>Connections for a Digital Non-Linear Editing System .....</b>	<b>57</b>
<b>Connections for a Cut Editing System .....</b>	<b>58</b>
<b>Connections for an A/B Roll Editing System .....</b>	<b>59</b>
<b>Connections for QSDI Dubbing .....</b>	<b>64</b>
<b>Connections for Analog Recording .....</b>	<b>65</b>
<b>Adjusting the Sync and Subcarrier Phases .....</b>	<b>66</b>

## Chapter 6

### Maintenance and Troubleshooting

<b>Maintenance .....</b>	<b>69</b>
Condensation .....	69
Regular Checks .....	69
Head Cleaning .....	70
<b>Troubleshooting .....</b>	<b>71</b>
Error Messages .....	73
Alarm Messages .....	73

## Appendix

<b>Notes on Use .....</b>	<b>77</b>
<b>Specifications .....</b>	<b>78</b>
<b>Glossary .....</b>	<b>81</b>
<b>Index .....</b>	<b>83</b>

# Features

The DSR-80/80P is a 1/4-inch digital video cassette recorder that uses the DVCAM digital recording format. This system achieves stable, superb picture quality by digitally processing video signals that are separated into color difference signals and luminance signals (component method).

The DSR-80/80P unit is equipped with the variety of functions that are needed for videocassette recorders and players used in professional digital video editing systems. It supports the ClipLink™ function developed by Sony Corporation for highly efficient video editing. When connected to a Sony EditStation™, the unit serves as part of a powerful non-linear editing system<sup>1)</sup>.

The unit is also equipped with a full-fledged analog interface to support hybrid systems that combine conventional analog equipment with digital equipment.

The DSR-80/80P's main features are described below.

## DVCAM Format

DVCAM is based on the consumer DV format, which uses the 4:1:1 component digital format, and provides a 1/4-inch digital recording format for professional use.

## High picture quality, high stability

Video signals are separated into color difference signals and luminance signals, which are encoded and compressed to one-fifth size before being recorded to ensure stable and superb picture quality.

Because the recording is digital, multi-generation dubbing can be performed with virtually no deterioration of quality.

## Wide track pitch

The recording track pitch is 15 μm, fully 50 percent wider than the DV format's 10-μm track pitch. Thanks to this feature, the DVCAM format sufficiently meets the reliability and precision requirements of professional editing.

## High-quality PCM digital audio

PCM recording makes for a wide dynamic range and a high signal-to-noise ratio, thereby enhancing sound quality.

There are two recording modes: 2-channel mode (48-kHz sampling and 16-bit quantization), which offers sound quality equivalent to the DAT (Digital Audio Tape) format, or 4-channel mode (32-kHz sampling and 12-bit quantization).

## Playback compatibility with DV format

A DV cassette recorded on a DV-format VCR can be played back on this unit. (Cassettes recorded in LP mode cannot be played back.)

## Choice of two cassette sizes

The unit can use both standard-size and mini-size DVCAM cassettes.

- According to cassette size, it automatically changes the position of the reel drive plate.
- The maximum recording/playback times are 184 minutes for standard size cassettes and 40 minutes for mini-size cassettes.

### 1) Non-linear editing

This is an editing method that uses video and audio signals that have been digitally encoded and recorded on a hard disk as digital data. When compared with conventional (linear) editing methods, non-linear editing offers vastly improved efficiency in editing operations, such as by eliminating tape transport time.

## A Wealth of Interfaces

### Digital interfaces

The unit provides the following two digital interfaces.

- **SDTI (QSDI)<sup>1)</sup>** : This interface enables SDTI (QSDI)-format video, audio and time code signals to be transferred between this unit and the Sony EditStation at normal speed.
- **AES/EBU interface** : This interface enables AES/EBU-format digital audio signals to be input and output.

As an option, you can also use the SDI (Serial Digital Interface) as an interface for D1 (component) format digital video and audio signals.

### Analog interfaces

The unit also comes with analog interfaces enabling it to be connected to analog video and audio equipment.

- **Analog video** : These interfaces include a component interface (can be switched to RGB), composite interface, and S-video interface.
- **Analog audio** : 4-channel input and 4-channel output are both provided.

## Facilities for High-efficiency Editing

The unit provides an abundance of functions that enhance editing efficiency and precision.

### Supports ClipLink function

In response to commands sent from the EditStation, index pictures that are recorded on tape or ClipLink log data that is recorded in the cassette memory can be transferred to the EditStation. The EditStation operator can then efficiently use these pictures and data in a preliminary editing session.

*For more information about the ClipLink function, refer to the “ClipLink™ Guide” also supplied with this unit.*

### Internal time code generator/reader

The unit contains a time code generator/reader which can generate and read longitudinal time code (LTC) in the SMPTE format (DSR-80) or EBU format (DSR-80P), to ensure frame-accurate editing.

When the unit is equipped with an optional DSBK-130/130P Time Code Input/Output Board, it can output the time code read from tape as analog (LTC) signal, and receive externally generated time code (LTC).

### Remote control

The unit can be operated by remote control from an editing controller that supports the RS-422A interface or from an optional SIRCS<sup>2)</sup>-system remote controller such as the DSRM-10 or SVRM-100A.

### High-speed search function

The unit has a picture search function that allows you to view color picture at playback speeds up to 32 times normal speed in forward and reverse directions.

When remote-controlling this unit in shuttle mode from an editing controller or a remote controller, you can search at any speed in the range 0 (still) to 32 times normal in both directions. You can also search frame-by-frame in jog mode.

At search speeds up to 5 times normal, you can also hear playback audio.

1) QSDI is a type of SDTI.

SDTI is the name of a standard interface established as SMPTE 305M.

This unit uses SDTI to transmit DV data, and the input/output connectors are labeled “SDTI(QSDI)”.

In indicator and menu indications, however, the “SDTI(QSDI)” name is shortened to “QSDI”.

In the remainder of this manual, the short form (“QSDI”) is used.

2) **SIRCS (Sony Integrated Remote Control System)**

A command protocol to remote control Sony professional videocassette recorders/players.

---

## Digital slow-motion playback

Using the frame memory function, the unit can show noise-free slow-motion playback at speeds ranging from 0 to  $\frac{1}{5}$  normal in both directions. Frame-by-frame or field-by-field playback of still pictures is also possible.

---

## Jog audio function

When in jog mode, audio can be monitored at playback speeds ranging from normal to  $\frac{1}{30}$  normal in both directions. The audio signals are once stored in memory and then played back at the same rate as the search speed. This allows you to use audio playback to find the desired edit points.

---

## Built-in TBC (Time Base Corrector)

A digital TBC is built in to ensure jitter-free video output during analog editing.

## Other Features

---

### Menu system for functionality and operation settings

The unit provides a menu system to make its various functions easier to use and set up its operation conditions.

---

### Superimposition function

Time code numbers, operation mode indications, menus, error messages, and other text data can be superimposed and output in analog composite video signals.

---

## Easy maintenance functions

- Self-diagnostic/alarm function : This function automatically detects setup and connection errors, operation faults, and other problems. It also displays a description of the problem, its cause, and the recommended response on the video monitor screen or time counter display.
- Digital hours meter : The unit's digital hours meter functions include four kinds of tally operations for operating hours, head drum usage hours, tape transport hours, and tape threading/unthreading times. The tally results can be viewed on the video monitor or the time counter display.

---

## Rack mountable

When you use the optional RMM-130 Rack Mount Kit, you can mount this unit onto an EIA-standard 19-inch rack (height = 4 units).

## Optional Accessories

---

### DSBK-120/120P SDI (Serial Digital Interface) Input/Output Board

When installed in the DSR-80/80P, this board enables digital video and audio signals in the D1 format to be input to and output from the unit.

---

### DSBK-130/130P Time Code Input/Output Board

When installed in the DSR-80/80P, this board enables SMPTE or EBU-format time code (LTC) to be input to and output from the unit.

---

### RMM-130 Rack Mount Kit

This kit can be used to mount the DSR-80/80P onto an EIA-standard 19-inch rack.

# Location and Function of Parts

## Front Panel

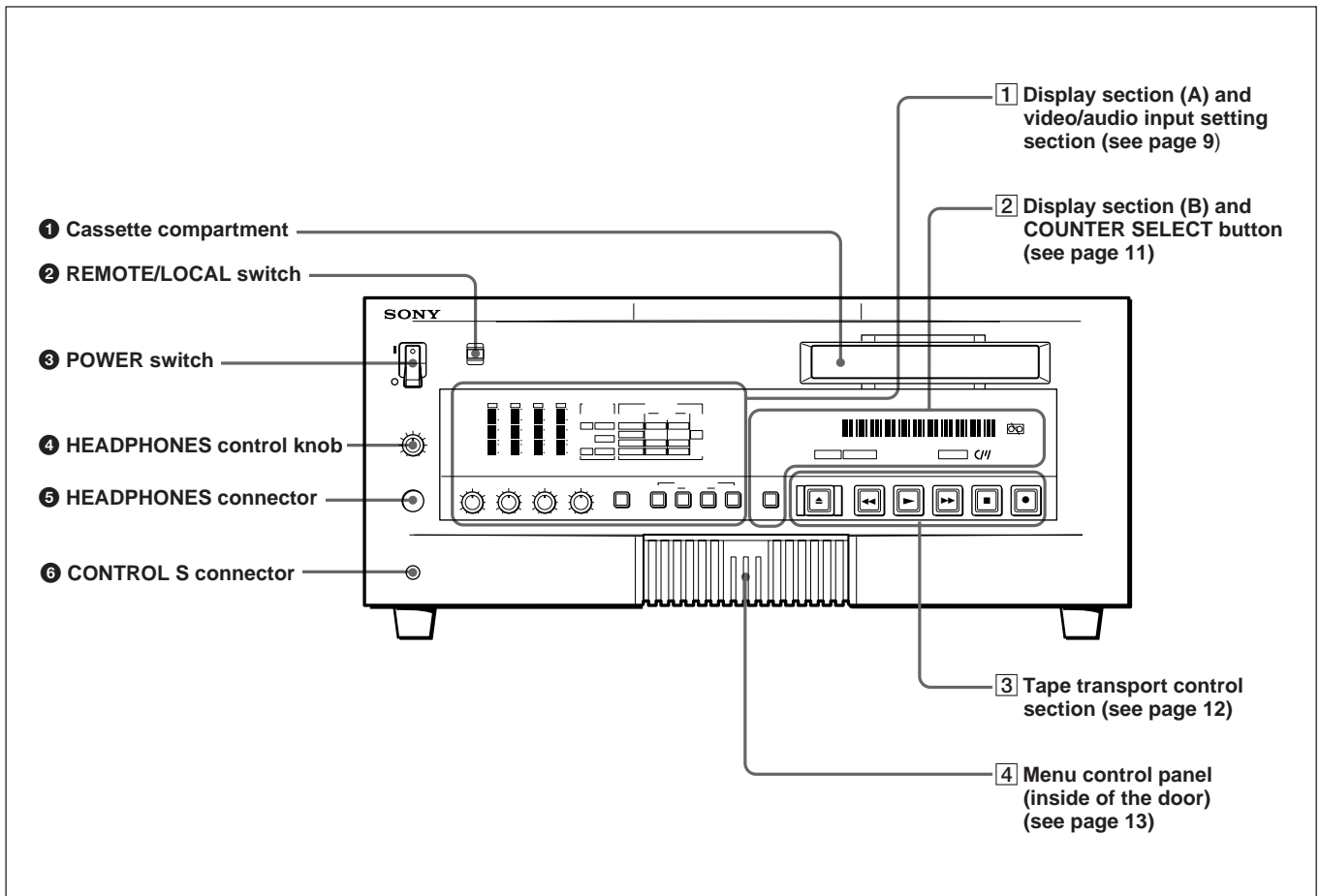

### 1 Cassette compartment

Accepts standard-size or mini-size DVCAM digital videocassettes. When using a mini-size cassette, insert it into the middle of the compartment.

*For details of usable cassettes, see page 22.*

### 2 REMOTE/LOCAL switch

Selects whether the unit is operated from its front panel or from external (remote) equipment.

**REMOTE :** The unit is operated from an editing controller connected to the REMOTE connector on the rear panel.

**LOCAL :** The unit is operated from its front panel or from a SIRCS-system remote controller connected to the CONTROL S connector on the front panel.

### 3 POWER switch

Press on the “I” side to power on the unit. This causes the audio level meter and time counter display to light. Press on the “O” side to power off the unit.

### 4 HEADPHONES control knob

Controls the volume of the headphones connected to the HEADPHONES connector.

### 5 HEADPHONES connector (stereo phone jack)

Connect a stereo headphones for headphone monitoring during recording or playback. The audio signal you want to monitor can be selected with the MONITOR SELECT switches on the menu control panel **4**.

### 6 CONTROL S connector (stereo minijack)

Connect a SIRCS-system remote controller such as the DSRM-10 or SVRM-100A.

## 1 Display section (A) and video/audio input setting section

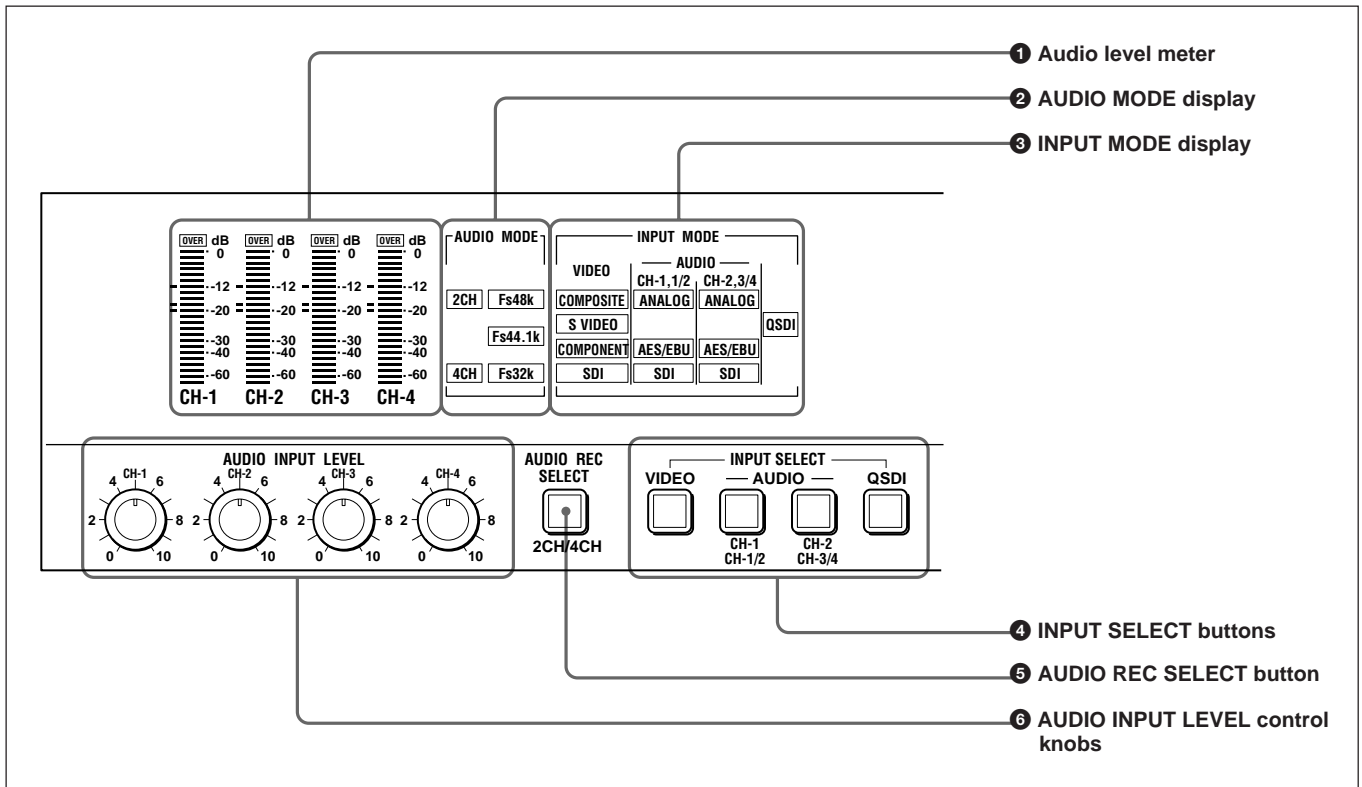

### 1 Audio level meter

Indicates the recording level during recording or EE mode<sup>1)</sup> and the playback level during playback. When the audio level exceeds 0 dB, the OVER indicator lights.

The short bars to the left of some level indication bars indicate that those levels are reference audio recording levels.

### 2 AUDIO MODE display

Indicates the audio mode during playback or recording or while in EE mode.

- During playback it indicates the audio mode in which the tape was recorded.
- During recording or while in EE mode, it indicates the currently selected audio recording mode. The AUDIO REC SELECT button is used for audio recording mode selection.

**2CH and Fs48k indicators** : Light during playback of a tape recorded in two-channel mode (48 kHz), or during two-channel mode (48 kHz) recording.

**2CH and Fs44.1k indicators** : Light during playback of a tape recorded in two-channel mode (44.1 kHz).

**4CH and Fs32k indicators** : Light during playback of a tape recorded in four-channel mode (32 kHz), or during four-channel mode (32 kHz) recording.

### 1) EE mode

“EE” stands for “Electric to Electric”. When in this mode, the video and audio signals that are input to the VCR’s recording circuitry do not pass through any magnetic conversion circuits but instead are output via electric circuits only. This mode is used to check input signals and adjust input levels.

### ③ INPUT MODE display

Indicates the format of the currently selected video and audio input signals.

**VIDEO indicators :** The corresponding indicator lights when the selected video input signal is in the composite analog, S-video, component analog, or SDI (serial digital interface) format.

**AUDIO CH-1, 1/2 indicators :** The ANALOG, AES/EBU or SDI indicator lights for the corresponding format of the selected audio signal being input to channel 1 (when in 2-channel mode) or to channels 1 and 2 (when in 4-channel mode).

**AUDIO CH-2, 3/4 indicators:** The ANALOG, AES/EBU, or SDI indicator lights for the corresponding format of the selected audio signal being input to channel 2 (when in 2-channel mode) or to channels 3 and 4 (when in 4-channel mode).

**QSDI :** Lights when QSDI-format video and audio input signals have been selected. When QSDI is selected, all of the indicators in the VIDEO and AUDIO groups go off.

### ④ INPUT SELECT buttons

Select video input signals and audio input signals.

**VIDEO button :** Each press of this button cycles through four video signal selection options: composite analog, S-video, component analog, and SDI. When you select one of these options, the corresponding VIDEO indicator in the INPUT MODE display lights up.

**AUDIO CH-1, CH-1/2 button :** Each press of this button cycles through three audio signal selection options for audio channel 1 (when in 2-channel mode) or channels 1 and 2 (when in 4-channel mode): analog, AES/EBU, and SDI. When you select one of these options, the corresponding AUDIO indicator in the INPUT MODE display lights up.

**AUDIO CH-2, CH-3/4 button :** Each press of this button cycles through three audio signal selection options for audio channel 2 (when in 2-channel mode) or channels 3 and 4 (when in 4-channel mode): analog, AES/EBU, and SDI. When you select one of these options, the corresponding AUDIO indicator in the INPUT MODE display lights up.

**QSDI :** Press this button to select QSDI signals.

If the selected signal (except for analog audio) is not supplied to the appropriate connector, the corresponding indicator flashes in the INPUT MODE display.

If the unit is not equipped with an optional DSBK-120/120P SDI Input/Output Board, no SDI indicators light in the INPUT MODE display no matter how many times you press the INPUT SELECT buttons.

### ⑤ AUDIO REC (recording mode) SELECT button

Selects the audio mode for recording. Each press toggles between 2-channel mode and 4-channel mode, and the indicator corresponding to the selected option lights in the AUDIO MODE display.

#### Note

This button works only when the unit is in EE mode.

### ⑥ AUDIO INPUT LEVEL control knobs

When recording, you can use these knobs to set audio input levels for CH-1 (channel 1), CH-2, CH-3 and CH-4, respectively.

You can make these knobs inoperative for an AES/EBU, SDI or QSDI format digital audio input by setting “DIGITAL INPUT” under the AUDIO CONTROL menu item to “BYPASS”.

*On how to use the menu, see Chapter 4 “Menu Settings”.*

## 2 Display section (B) and COUNTER SELECT button

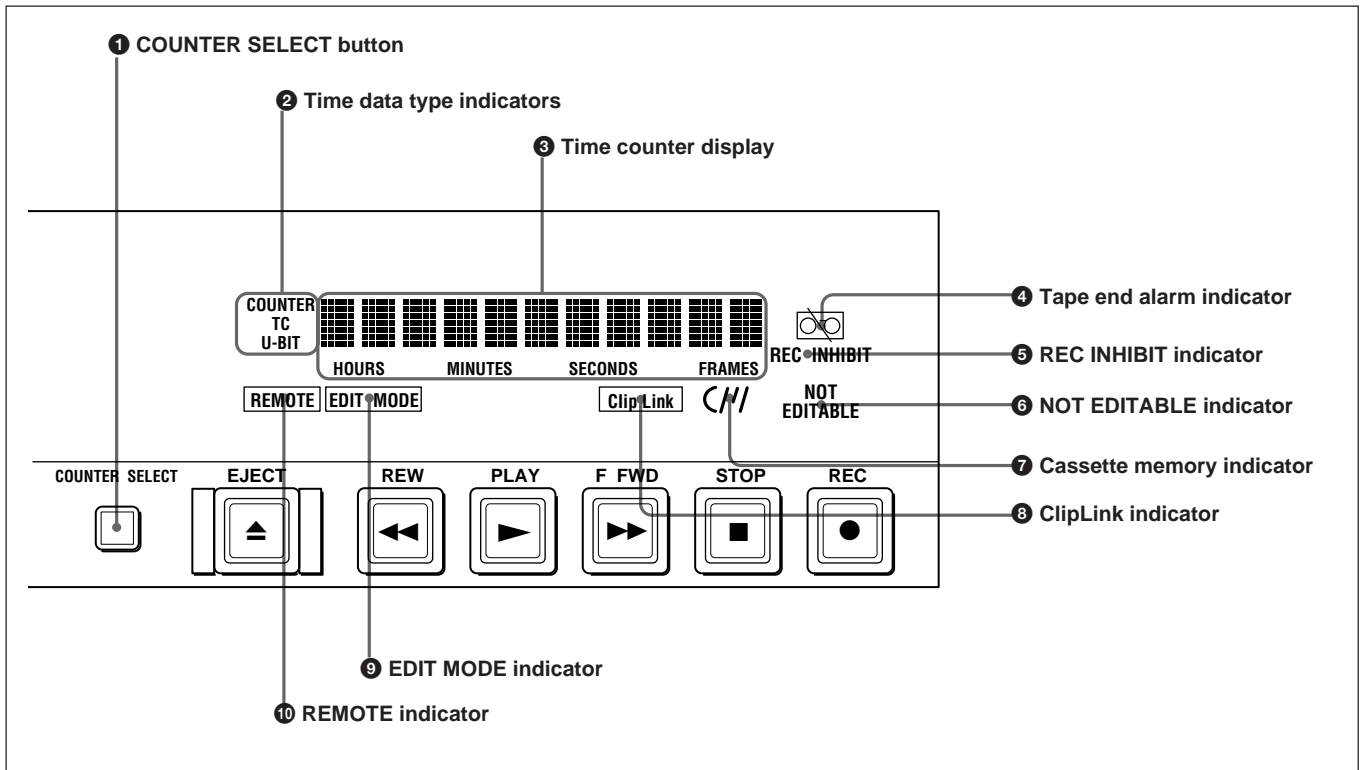

### 1 COUNTER SELECT button

Selects the type of time data to be shown in the time counter display. Each press of this button cycles through three indicator display options: COUNTER (CNT: count value of the time counter), TC (time code), and U-BIT (user bits).

#### Note

If the REMOTE/LOCAL switch is set to REMOTE, the COUNTER SELECT button does not operate while the tape is moving. In this case, make the time data selection via the remote equipment that is connected to the REMOTE connector on the rear panel.

### 2 Time data type indicators

One of the three indicators (COUNTER, TC, and U-BIT) lights to indicate the type of time data currently shown in the time counter display.

**COUNTER** : CNT (count value of the time counter)

**TC** : SMPTE time code (DSR-80) or EBU time code (DSR-80P)

**U-BIT** : User bit data

### 3 Time counter display

Indicates the following:

- Time data : CNT (count value of the time counter), time code, or user bit data
- Digital hours meter's count value : time total for unit's operating hours, drum usage hours, etc., (selectable via the digital hours meter display menu).
- Error messages and alarm messages (*see page 73*)

### 4 Tape end alarm indicator

Starts flashing when the tape's remaining capacity is for about 2 minutes.

### 5 REC INHIBIT indicator

Lights when the REC/SAVE switch on the loaded cassette is in the SAVE position.

### 6 NOT EDITABLE indicator

Lights during playback of a tape that contains a DV-format recording. DV-format recordings can be used as source material for editing, but editing functions such as setting IN/OUT points cannot be used. This indicator also lights when the audio recording mode selected on this unit does not coincide with that of the loaded tape.

## Location and Function of Parts

### 7 Cassette memory indicator *C//*

Lights when a cassette provided with a memory chip (“cassette memory”) is loaded.

### 8 ClipLink indicator

Lights when a cassette is loaded on which ClipLink log data is stored in the cassette memory.

For details of ClipLink log data, refer to the “ClipLink™ Guide” also supplied with this unit.

### 9 EDIT MODE indicator

Lights when this unit is selected as the recorder VCR under the control of an editing controller connected to the REMOTE connector on the rear panel of the unit.

### 10 REMOTE indicator

Lights when the REMOTE/LOCAL switch on the front panel has been set to REMOTE.

## 3 Tape transport control section

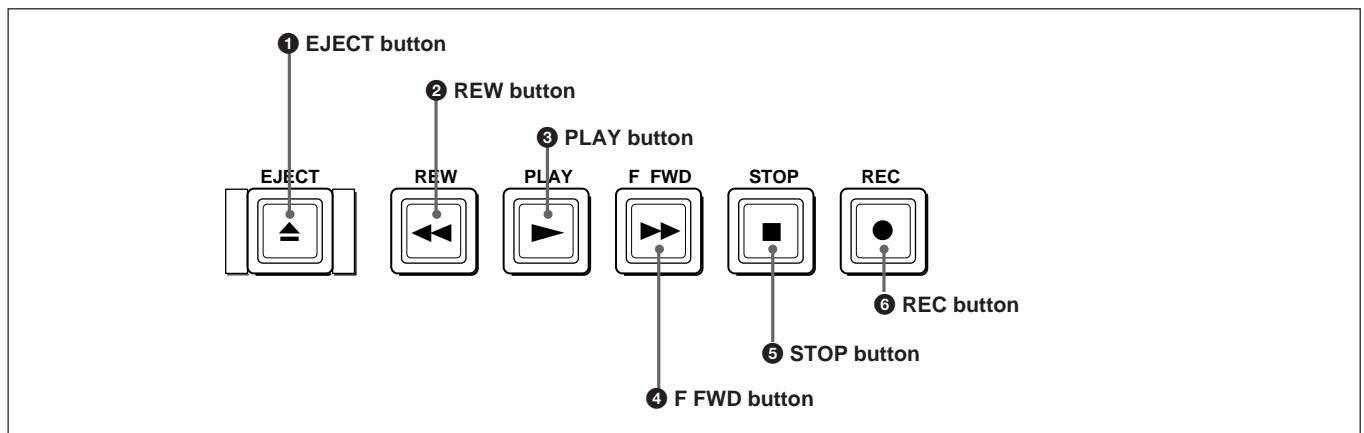

### 1 EJECT button

When you press this button, it lights and the cassette is automatically ejected after a few seconds.

### 2 REW (rewind) button

When you press this button, it lights and the tape starts rewinding. During rewind, the picture does not appear on the monitor.

However, if “F. FWD/REW” under the AUTO EE SELECT menu item is set to “PB”, holding down the REW button provides a picture search function at 32 times normal speed in reverse direction.

### 3 PLAY button

When you press this button, it lights and playback begins. If you press this button during recording or editing, the recording or editing operation is stopped and this unit enters playback mode.

### 4 F FWD (fast forward) button

When you press this button, it lights and the tape is fast forwarded. During fast forward, the picture does not appear on the monitor.

However, if “F. FWD/REW” under the AUTO EE SELECT menu item is set to “PB”, holding down the F FWD button provides a picture search function at 32 times normal speed in forward direction.

### 5 STOP button

Press this button to stop the current tape transport operation.

### 6 REC (record) button

When you press this button while holding down the PLAY button, it lights and recording begins.

#### Note

A menu setting has been selected at the factory so that no tape transport control buttons other than EJECT 1 and STOP 5 will work while the REMOTE indicator is lit on the front panel.

For details on changing menu settings, see “Changing Menu Settings” (page 51).

## 4 Menu control panel

The menu control panel is located on the inside of the door at the lower front of the unit. Press on the top of the door to open it.

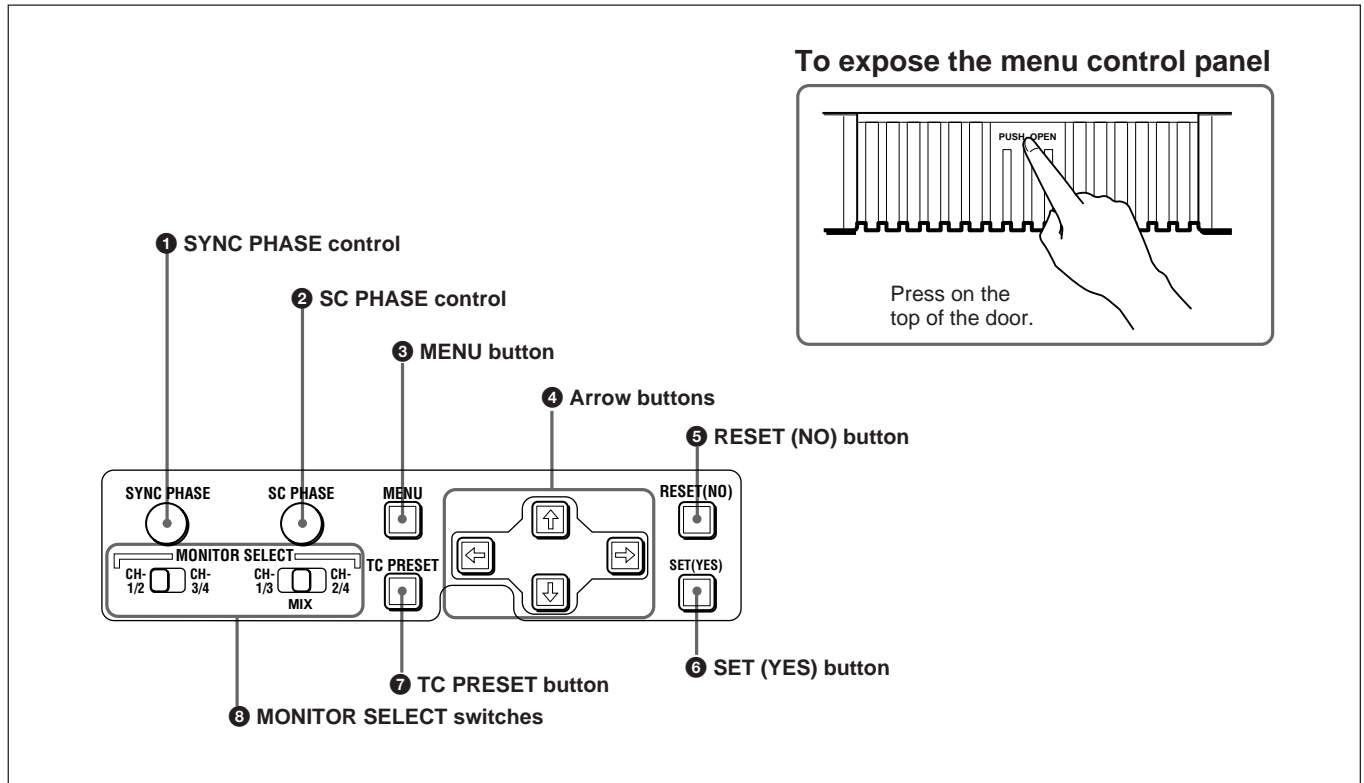

### 1 SYNC (synchronization) PHASE control

Turn this control to accurately adjust the synchronization phase of the output video signal of the unit with respect to the reference video signal. Use a cross-point (Phillips) screwdriver to turn it.

### 2 SC (subcarrier) PHASE control

Turn this control to accurately adjust the subcarrier phase of the composite video output signal of the unit with respect to the reference video signal. Use a cross-point (Phillips) screwdriver to turn it.

### 3 MENU button

Press this button to display the menu on the monitor screen and the time counter display. Press it again to return from the menu display to the usual display.

On how to use the menu, see chapter 4 "Menu Settings".

### 4 Arrow (↑ ↓ ← →) buttons

Use these buttons to move around the menu items, and also for setting time code and user bit data.

For details on setting time code and user bit data, see "Using the Internal Time Code Generator" (page 33).

### 5 RESET (NO) button

Press this button to:

- reset menu settings,
- reset the time data shown in the time counter display to zero, or
- send a negative response to the unit's prompts.

### 6 SET (YES) button

Press this button to:

- save new settings, such as selected menu items and time code settings, to the unit's memory, or
- send a positive response to the unit's prompts.

### 7 TC (time code) PRESET button

Use this button when setting time code's initial values and user bit data.

For details on setting time code and user bit data, see "Using the Internal Time Code Generator" (page 33).

# Location and Function of Parts

## 8 MONITOR SELECT switches

Use these switches to select the channels for audio output via the MONITOR AUDIO connector on the rear panel and the HEADPHONES connector on the front panel.

Use the left switch to select the basic channel setting, then use the right switch to select the output format (monaural, stereo, or mix).

The table at right lists the correspondence of left/right switch settings and channel/output format selections.

Switch setting		Selected channel and output format	
Left switch	Right switch	HEADPHONES connector	MONITOR AUDIO connector
CH-1/2 <input type="checkbox"/> CH-3/4	CH-1/3 <input type="checkbox"/> CH-2/4 MIX	Channel 1 only (monaural)	Channel 1 only (monaural)
	CH-1/3 <input type="checkbox"/> CH-2/4 MIX	Channels 1 and 2 (stereo)	Channels 1 and 2 (mix)
	CH-1/3 <input type="checkbox"/> CH-2/4 MIX	Channel 2 only (monaural)	Channel 2 only (monaural)
CH-1/2 <input type="checkbox"/> CH-3/4	CH-1/3 <input type="checkbox"/> CH-2/4 MIX	Channel 3 only (monaural)	Channel 3 only (monaural)
	CH-1/3 <input type="checkbox"/> CH-2/4 MIX	Channels 3 and 4 (stereo)	Channels 3 and 4 (mix)
	CH-1/3 <input type="checkbox"/> CH-2/4 MIX	Channel 4 only (monaural)	Channel 4 only (monaural)

## Rear Panel

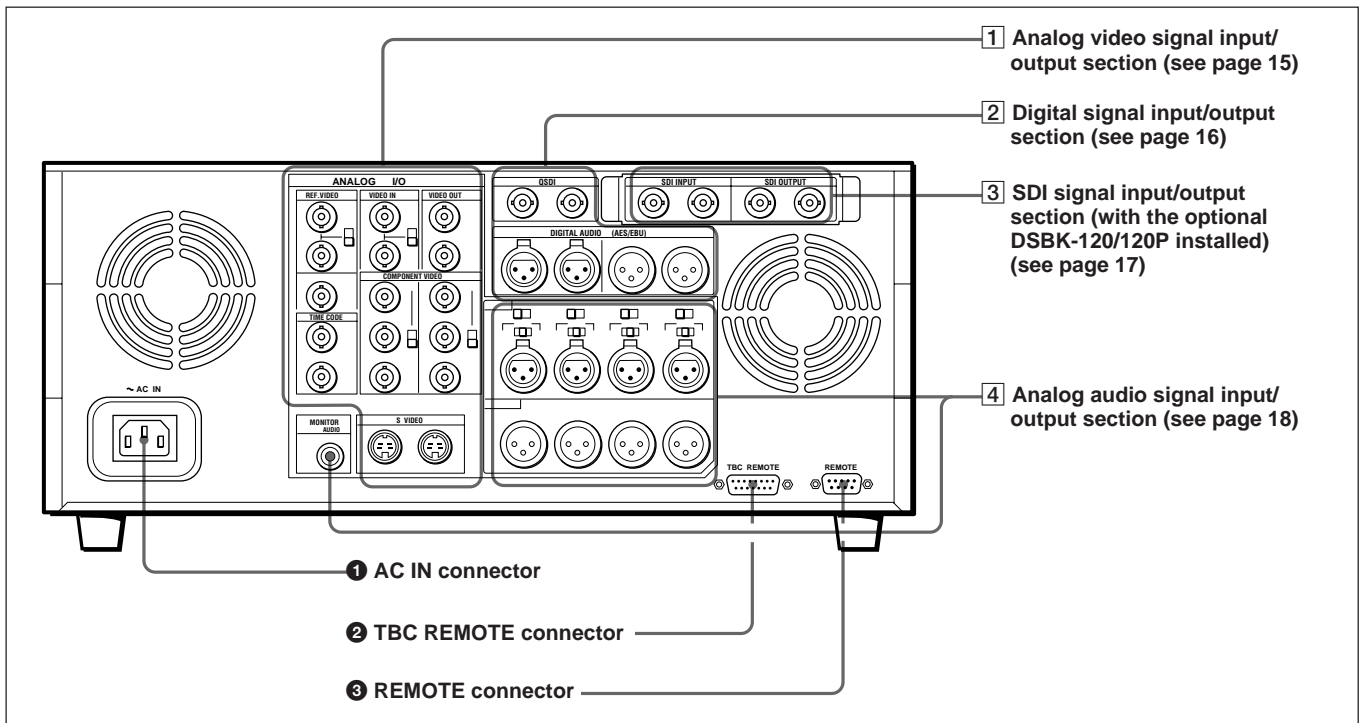

### 1 AC IN connector

Connect to an AC power outlet using the supplied power cord.

### 2 TBC (time base corrector) REMOTE connector (15-pin)

To remote-control the built-in time base corrector, connect an optional TBC remote controller such as the UVR-60/60P, BK-2006/2007 or BVR-50/50P.

### Notes

- Be sure to power off this unit before connecting the TBC remote controller to the TBC REMOTE connector.
- TBC remote control can be applied only to the analog video outputs from the VIDEO OUT 1 and 2 (SUPER) connectors 6, COMPONENT VIDEO Y, R-Y, and B-Y/RGB OUT connectors 8, and S VIDEO OUT connector 10 in the analog video signal input/output section 1 on the next page.

### 3 REMOTE connector (9-pin)

When controlling this unit from an editing controller such as the ES-7, PVE-500, BVE-600/800/910, or RM-450/450CE, connect the unit to the editing controller via this connector using the supplied 9-pin remote control cable.

## 1 Analog video signal input/output section

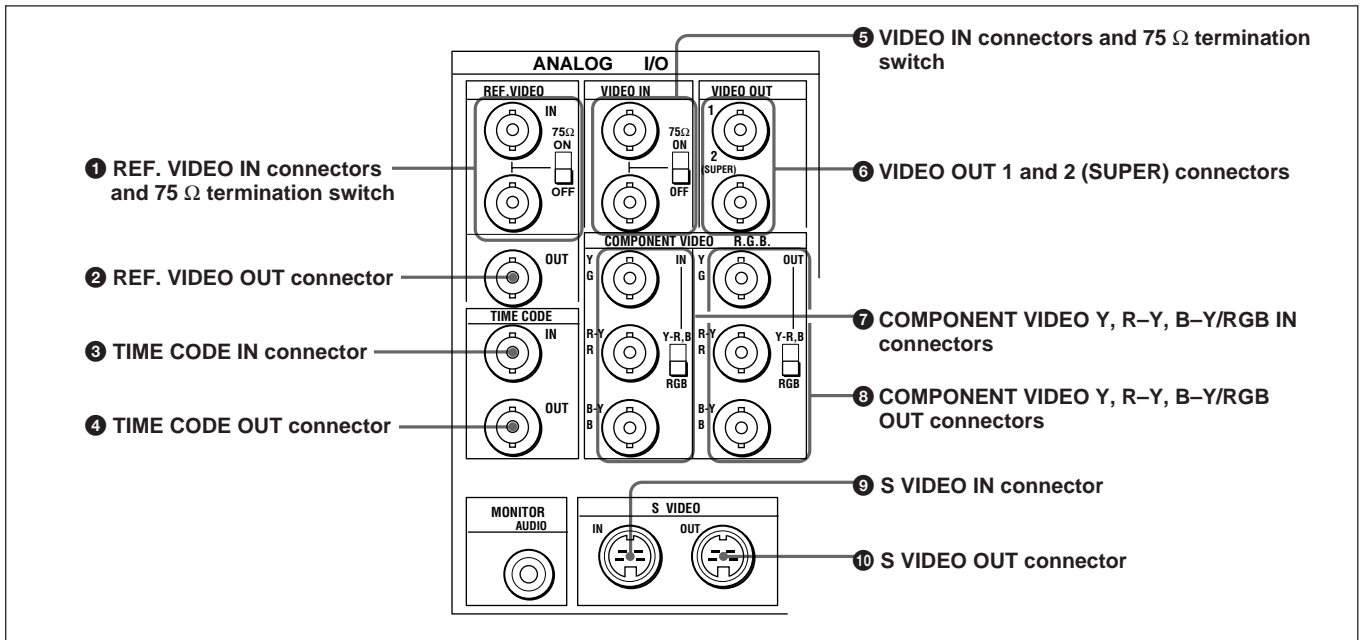

### 1 REF. (reference) VIDEO IN (input) connectors (BNC type) and 75 $\Omega$ termination switch

Input a reference video signal to one of these connectors. The two connectors can be used for a loop-through connection. When making a loop-through connection, set the 75  $\Omega$  termination switch to OFF and when not, set the switch to ON.

When using the COMPONENT VIDEO Y, R–Y, and B–Y/RGB IN connectors 7 in four-wire mode (with no sync signal included in the green signal), input a sync signal to this connector.

### 2 REF. (reference) VIDEO OUT (output) connector (BNC type)

Outputs a reference video signal.

When using the COMPONENT VIDEO Y, R–Y, and B–Y/RGB OUT connectors 8 in four-wire mode (with no sync signal included in the green signal), this connector outputs a sync signal.

### 3 TIME CODE IN connector (BNC type)

Input SMPTE time code (DSR-80) or EBU time code (DSR-80P) externally generated.

### 4 TIME CODE OUT connector (BNC type)

When the unit is in normal-speed playback mode, this connector outputs the time code read from the tape as an analog (LTC) signal. When the unit is in any other mode, the connector outputs no signal.

#### Note

The TIME CODE IN connector 3 and TIME CODE OUT connector 4 can only be used when an optional DSBK-130/130P Time Code Input/Output Board is installed in this unit.

### 5 VIDEO IN connectors (BNC type) and 75 $\Omega$ termination switch

Input a composite video signal to one of these connectors. The two connectors can be used for a loop-through connection. When making a loop-through connection, set the 75  $\Omega$  termination switch to OFF and when not, set the switch to ON.

## Location and Function of Parts

### 6 VIDEO OUT 1 and 2 (SUPER) connectors (BNC type)

Output a composite video signal. When “CHARA. DISPLAY” under the DISPLAY CONTROL menu item has been set to “ON” (factory default setting), a character signal is superimposed on the video signal that is output from the VIDEO OUT 2 (SUPER) connector.

### 7 COMPONENT VIDEO Y, R–Y, B–Y/RGB IN connectors (BNC type)

Input a component video (Y, R–Y, B–Y) signal or RGB signal, according to the setting of the selector switch.

**Y** : Luminance signal

**R–Y and B–Y** : Color difference signals

### 8 COMPONENT VIDEO Y, R–Y, B–Y/RGB OUT connectors (BNC type)

Output a component video (Y, R–Y, B–Y) signal or RGB signal, according to the setting of the selector switch. The RGB signal may also have a sync signal included in the green signal, according to a menu setting.

**Y** : Luminance signal

**R–Y and B–Y** : Color difference signals

*For details, see the menu item VIDEO CONTROL, setting “SYNC ON GREEN”. (Page 47)*

### 9 S VIDEO IN connector (4-pin)

Input an S-video signal with separated Y (luminance) and C (chroma: 3.58 MHz for DSR-80 and 4.43 MHz for DSR-80P) components.

### 10 S VIDEO OUT connector (4-pin)

Outputs an S-video signal with separated Y (luminance) and C (chroma: 3.58 MHz with DSR-80 and 4.43 MHz with DSR-80P) components.

## 2 Digital signal input/output section

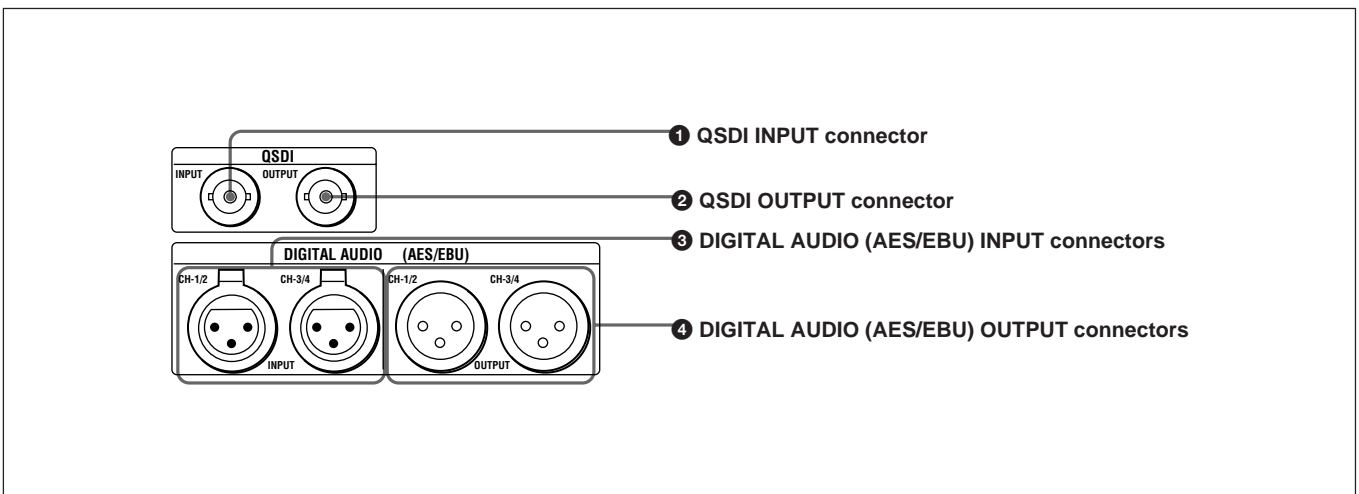

### 1 QSDI INPUT connector (BNC type)

Input video, audio and time code signals in the QSDI format.

### 2 QSDI OUTPUT connector (BNC type)

Outputs video, audio and time code signals in the QSDI format when the unit is in playback mode, but outputs no EE signals.

### Note

In search mode, this connector outputs unprocessed audio signals. If you are monitoring this audio signal on another device, the sound may be different from the playback output of this unit.

### 3 DIGITAL AUDIO (AES/EBU) INPUT connectors (XLR 3-pin, female)

Input digital audio signals in the AES/EBU format.

#### 4 DIGITAL AUDIO (AES/EBU) OUTPUT connectors (XLR 3-pin, male)

Output digital audio signals in the AES/EBU format.

#### 3 SDI (Serial Digital Interface) signal input/output section (with the optional DSBK-120/120P installed)

When an optional DSBK-120/120P SDI Input/Output Board is installed in the unit, this section can be used for inputting and outputting SDI signals.

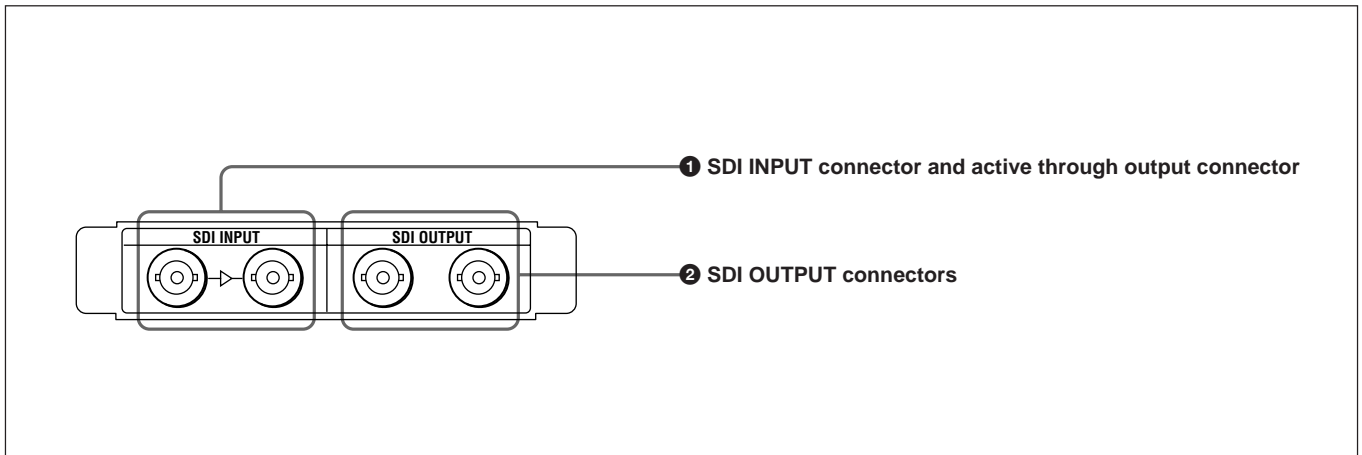

#### 1 SDI (Serial Digital Interface signal) INPUT connector and active through output connector (BNC type)

The left connector is for input of SDI-format digital video and audio signals. The right connector can be used as an active through output connector.

#### 2 SDI (Serial Digital Interface signal) OUTPUT connectors (BNC type)

Output SDI-format digital video and audio signals. The same signals are output from both connectors.

## 4 Analog audio signal input/output section

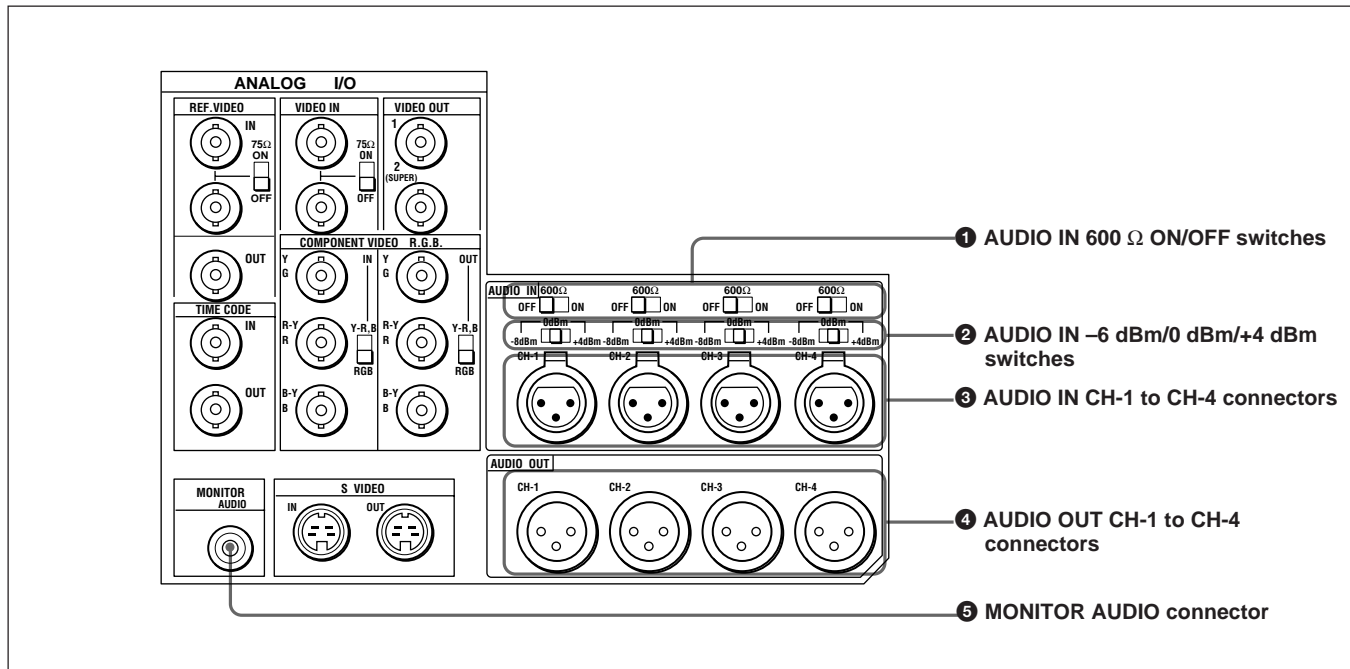

### 1 AUDIO IN 600 Ω ON/OFF switches

Use these switches to select either 600 Ω impedance (the ON setting) or 10-kΩ impedance (the OFF setting) for the AUDIO IN CH-1 to CH-4 connectors.

### 2 AUDIO IN -6 dBm/0 dBm/+4 dBm switches

Set these switches according to the levels of the signals input to the AUDIO IN CH-1 to CH-4 connectors.

### 3 AUDIO IN CH-1 (channel 1) to CH-4 connectors (XLR 3-pin, female)

Use these connectors to connect separate channels of audio input from a player VCR or other external audio equipment.

### 4 AUDIO OUT CH-1 (channel 1) to CH-4 connectors (XLR 3-pin, male)

Output channel-1 to channel-4 audio signals, respectively.

### 5 MONITOR AUDIO connector (RCA phono jack)

Outputs audio signals for monitoring. The audio signals to be output from this connector can be selected with the MONITOR SELECT switches on the menu control panel [4](#) (see page 13).

This section describes the necessary settings and operations to perform recording on this unit. The same settings and operations apply whether you are using the unit as part of an editing system, for dubbing<sup>1)</sup>, or as a stand-alone recorder. For the necessary connections for recording and the settings not covered in this section, see Chapter 5 “Connections and Settings”.

## Settings for Recording

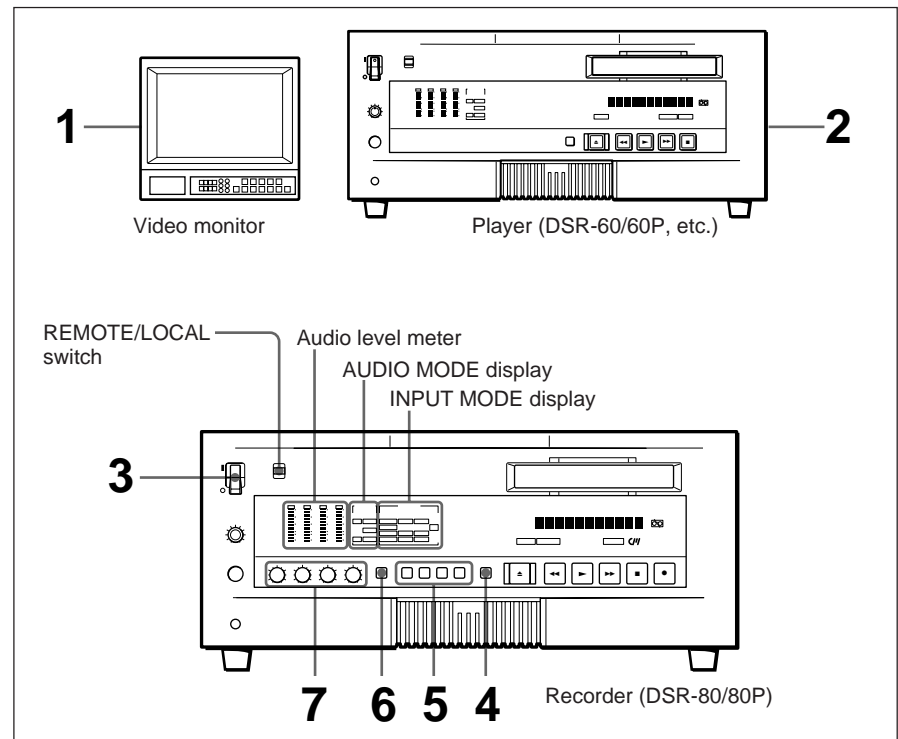

**Note**

When controlling this unit from an editing controller, set the REMOTE/LOCAL switch to “REMOTE”. When not, set the switch to “LOCAL”.

**1** Power on the video monitor, then set the monitor’s input switches according to the input signals from this unit.

**2** Set up the player to play back a tape.

*For details, refer to your player’s operating instructions.*

**3** Power on this unit by pressing on the “I” side of the POWER switch.

*(Continued)*

1) For dubbing of QSDI format signals, use the auto mode (AUTO FUNCTION) execution menu item QSDI DUBBING.

*For details, see the section “Dubbing Signals in QSDI Format” on page 38.*

- 4** When the REMOTE/LOCAL switch is set to “LOCAL”, use the COUNTER SELECT button to select the type of time data to be used.

Each press of this button cycles through three options : COUNTER (CNT value), TC (time code), and U-BIT (user bit data). The time data type indicator for each option lights as it is selected.

When the REMOTE/LOCAL switch is set to “REMOTE”, selection of the time data type is carried out at the editing controller.

- 5** Select the formats of video and audio input signal to be recorded. Press INPUT SELECT buttons to select the desired signal formats. Each selection is shown by a lit indicator in the INPUT MODE display.

Video input signal (input connector)	Corresponding INPUT SELECT button	Lit indicator in INPUT MODE display
Composite signal (VIDEO IN)	VIDEO	COMPOSITE in VIDEO group
Separated Y/C signal (S VIDEO IN)	VIDEO	S VIDEO in VIDEO group
Component signal (COMPONENT VIDEO IN)	VIDEO	COMPONENT in VIDEO group
SDI signal (SDI INPUT)	VIDEO	SDI in VIDEO group
QSDI signal (QSDI INPUT)	QSDI	QSDI

Audio input signal (input connector)	Corresponding INPUT SELECT button	Lit indicator in INPUT MODE display
Analog signal (AUDIO IN CH-1 to CH-4)	AUDIO CH-1 CH-1/2, AUDIO CH-2 CH-3/4	ANALOG in AUDIO group
AES/EBU signal (DIGITAL AUDIO (AES/EBU) INPUT)	AUDIO CH-1 CH-1/2, AUDIO CH-2 CH-3/4	AES/EBU in AUDIO group
SDI signal (SDI INPUT)	AUDIO CH-1 CH-1/2, AUDIO CH-2 CH-3/4	SDI in AUDIO group
QSDI signal (QSDI INPUT)	QSDI	QSDI

**Caution**

Once you have started recording, you cannot change the input signal selection.

- 6** Select the audio mode.  
Press the AUDIO REC SELECT button to select the desired mode. Each selection is shown by lit indicators in the AUDIO MODE display.

Audio mode	Lit indicator in AUDIO MODE display
2-channel mode	2CH and Fs48k
4-channel mode	4CH and Fs32k

#### **Cautions**

- In the DVCAM format, there are two audio recording modes, with either two channels at 48 kHz or four channels at 32 kHz. It is not possible to select other modes (for example with four channels at 48 kHz).
- During editing, if a signal used in assemble or insert editing is in a different mode from the base tape, the signals will be discontinuous at the edit points, and correct editing will not be obtained. For this reason, audio editing between different modes is inhibited on this unit.  
For smooth editing operations, check the audio recording mode of the base tape beforehand.
- The audio mode selecting operation is only possible when the unit is in EE mode.
- Once you have started recording, you cannot change the audio mode selection.
- If on a tape there is a point where the audio mode is switched, you cannot perform an insert editing on that tape.

- 7** Use the AUDIO INPUT LEVEL control knobs to adjust audio input levels.  
Watching the audio level meter, adjust the level so that the meter does not indicate higher values than 0 dB when the audio signal is at its maximum.  
When the level exceeds 0 dB, the OVER indicator lights.

The factory-preset audio recording level is  $-20$  dB (DSR-80) or  $-18$  dB (DSR-80P). This setting can be changed to  $-12$  dB using the AUDIO CONTROL menu item.

*On how to use the menu, see Chapter 4 “Menu Settings”.*

## Usable Cassettes

This unit can use standard-size and mini-size DVCAM cassettes listed below.

Model name	Size
PDV-64ME/94ME/124ME/184ME	Standard size
PDVM-12ME/22ME/32ME/40ME	Mini size

The numbers in each model name indicate the maximum recording/playback time (in minutes) for each model. For example, the PDV-184ME has a maximum recording/playback time of 184 minutes.

### Notes

- If you insert an incorrect type of cassette, it will be automatically ejected.
- When operating this unit as a player, you can also use DV cassettes on the unit. However, it is the best choice to always use DVCAM cassettes because they are more reliable than DV cassettes whatever your purpose may be: playback, editing, or long-period storage of recordings.
- Cassettes that have been recorded by a DV-format recorder can be played back on this unit but cannot be used for recording at editing operation such as the setting of edit points. When you insert such a cassette into this unit, the NOT EDITABLE indicator lights up on the front panel of the unit.

## DVCAM cassettes

The following figure illustrates the DVCAM cassette's appearance.

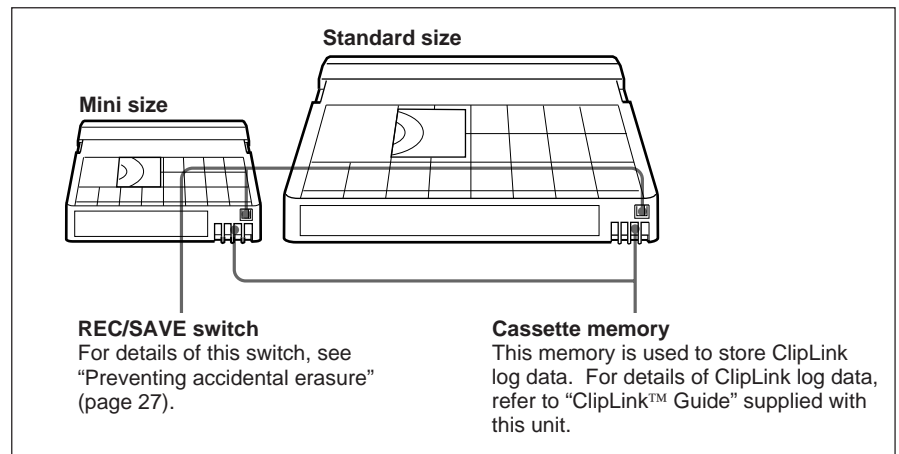

---

## Notes on using cassettes

- Before storing the cassette, rewind the tape to the beginning and be sure to put the cassette in its storage case, preferably on end instead of flat on its side. The storage case of a DVCAM cassette is specially designed to ensure a long-period storage of the tape.  
Storing a cassette in any other condition (not rewind, out of its case, etc.) may cause the video and audio contents to become damaged over time.
- If the cassette memory connector (contact point) becomes dirty, connection problems may occur and cause a loss of functions. Remove away any dust or dirt from this area before using the cassette.
- If the cassette is dropped on the floor or otherwise receives a hard impact, the tape may become slackened and may not record and/or play back correctly.

*For instructions on removing tape slack, see page 27.*

## Recording Procedure

This section describes the procedure to perform a recording on this unit, showing an example session in which playback signals coming from a player VCR will be recorded on the tape loaded in the unit.

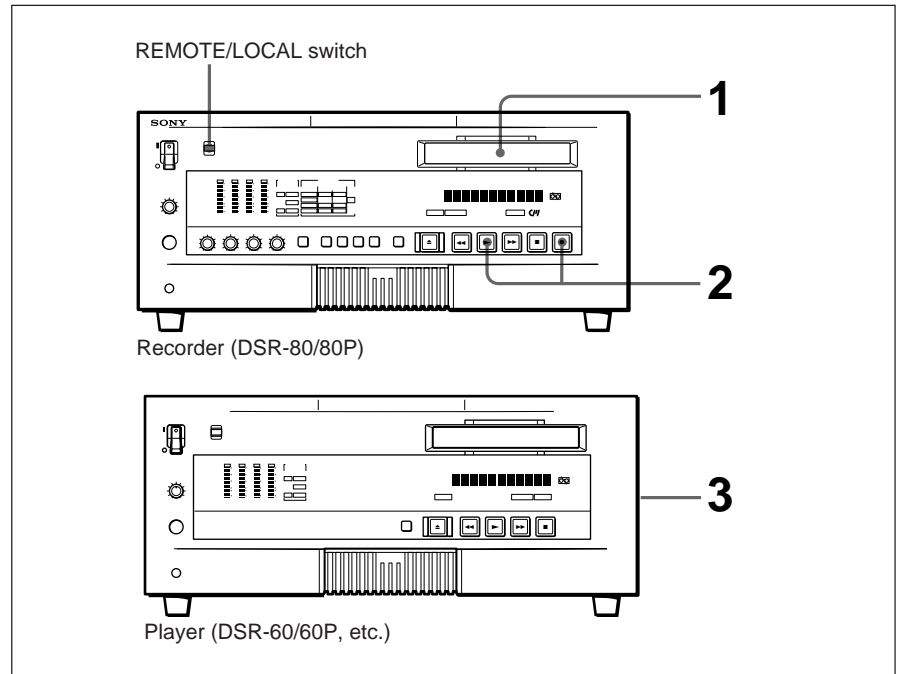

### Notes

- When controlling this unit from an editing controller, set the REMOTE/LOCAL switch to “REMOTE”. When not, set the switch to “LOCAL”.
- If you intend to use a tape recorded on this unit in a system comprising a DSR-85/85P and an ES-7 EditStation, it is recommended to record color bars on at least the first 40 seconds of the tape. When transferring digital signals from the DSR-85/85P to the ES-7 EditStation at quadruple speed, there must be recording for approximately 40 seconds before the IN point.

- 1 After checking the following items, hold the cassette so that the tape window is facing upward, then insert it into the recorder (this unit) as illustrated on the next page.

Item to check	See section
Make sure that the cassette’s “REC/SAVE” switch is set to “REC”.	“Preventing accidental erasure” (page 27).
Check for tape slack.	“Checking the tape for slack” (page 27).
Make sure that the “HUMID!” alarm is not shown in the display window.	“Condensation” (page 69)

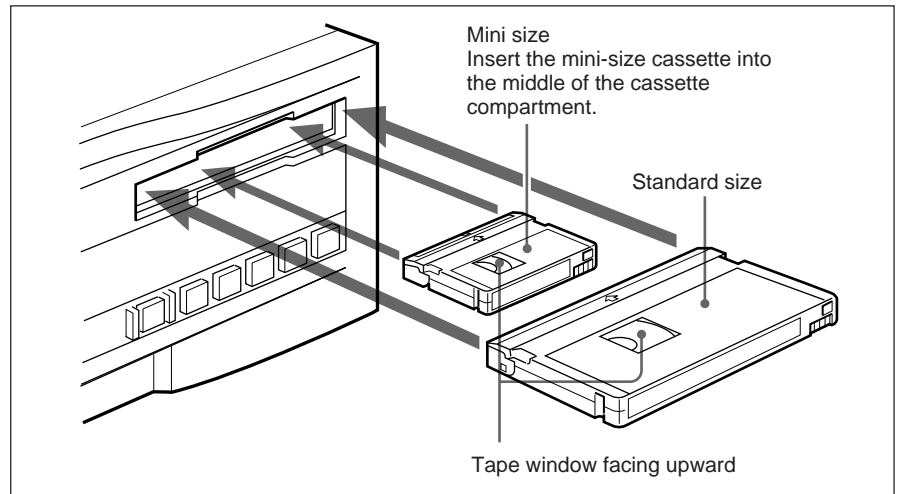

The cassette is automatically drawn into the unit and the tape is wound round the head drum. The tape is stationary while the head drum rotates, and the STOP button lights.

**If the REC INHIBIT indicator lights:**

It indicates that the loaded cassette's REC/SAVE switch has been set to SAVE. Press the EJECT button in the tape transport control section to remove the cassette, then set the cassette's REC/SAVE switch to REC and reload the cassette.

**Note**

Make sure that the unit's power is on when ejecting and loading cassettes.

- 2** Press and hold the REC button, and press the PLAY button.

This puts the unit into recording mode, and the tape starts moving.

- 3** Press the PLAY button on the player.

This starts the player's playback operation, at which point this unit starts recording the input playback signals.

**Cautions**

- Once you have started recording, you cannot change the audio mode selection.
- If on a tape there is a point where the audio mode is switched, you cannot perform an insert editing on that tape.

## If the following indicators light when a cassette is loaded

Indicator	It means:
Cassette memory indicator C//	The loaded cassette contains a cassette memory.
ClipLink indicator	<p>There is ClipLink log data stored in the cassette memory on the loaded cassette.</p> <p><b>Caution</b></p> <p>With such a cassette, execution of recording may destroy the ClipLink log data.</p>
NOT EDITABLE indicator	<p>The recording format of the tape is "DV". Replace the tape with one that has been recorded in "DVCAM" format when the unit is a recorder for editing.</p> <p>The audio recording mode selected on this unit does not coincide with that of the tape.</p> <ul style="list-style-type: none"> <li>• When your current purpose is recording, you can use the tape as it is.</li> <li>• When your current purpose is editing, set the unit for the same audio recording mode as with the tape. (For more details, see "Troubleshooting" (page 71).)</li> </ul>

For this purpose:	Do this:
Stop recording	Press the STOP button. The unit enters stop mode, and will automatically switch to standby off mode after 8 minutes.
Remove the cassette	Press the EJECT button. After a few seconds, the tape is unwound from the head drum and the cassette is automatically ejected. If a CNT value is shown on the time counter display (assuming the time data type indicator "COUNTER" is lit), the CNT value is reset.
Inhibit the unit from outputting text information (time data, operation mode indications, etc.) to the video monitor.	Change the menu settings. See "CHARA. DISPLAY" (page 43) in Chapter 4 "Menu Settings".
Change the time period before the unit switches to standby off mode from stop mode	Change the menu settings. See "TAPE PROTECTION" (page 46) in Chapter 4 "Menu Settings".

---

## Preventing accidental erasure

Set the REC/SAVE switch on the cassette to SAVE to prevent accidental erasure of recorded contents.

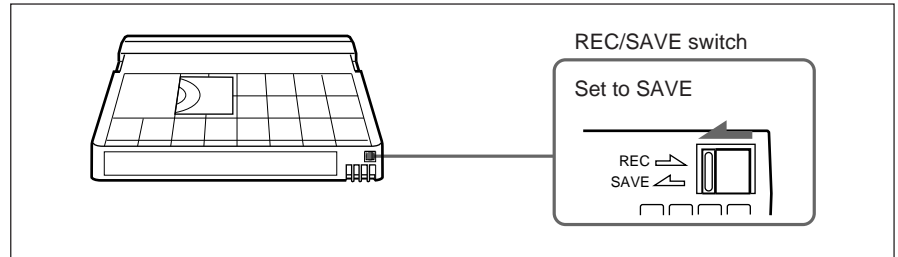

### To enable re-recording

Set the cassette's REC/SAVE switch to REC.

If you insert a cassette into the unit when this switch is set to SAVE, the unit will not record when you press the PLAY button while holding down the REC button.

---

## Checking the tape for slack

Using a paper clip or a similar object, turn the reel gently in the direction shown by the arrow. If the reel does not move, there is no slack. Insert the cassette into the cassette compartment, and after about 10 seconds take it out.

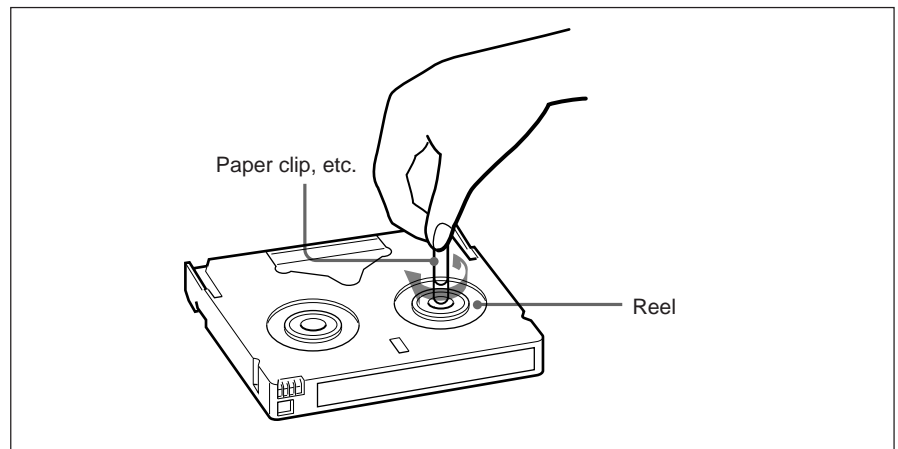

---

## No double insertion of cassettes

When you insert a cassette, the orange lock-out plate appears in the cassette compartment to prevent double insertion.

This section describes the necessary settings and operations to perform playback on this unit. The same settings and operations apply whether you are using the unit as part of an editing system, for dubbing, or as a stand-alone player VCR. For the necessary connections for playback and the settings not covered in this section, see Chapter 5 “Connections and Settings”.

## Settings for Playback

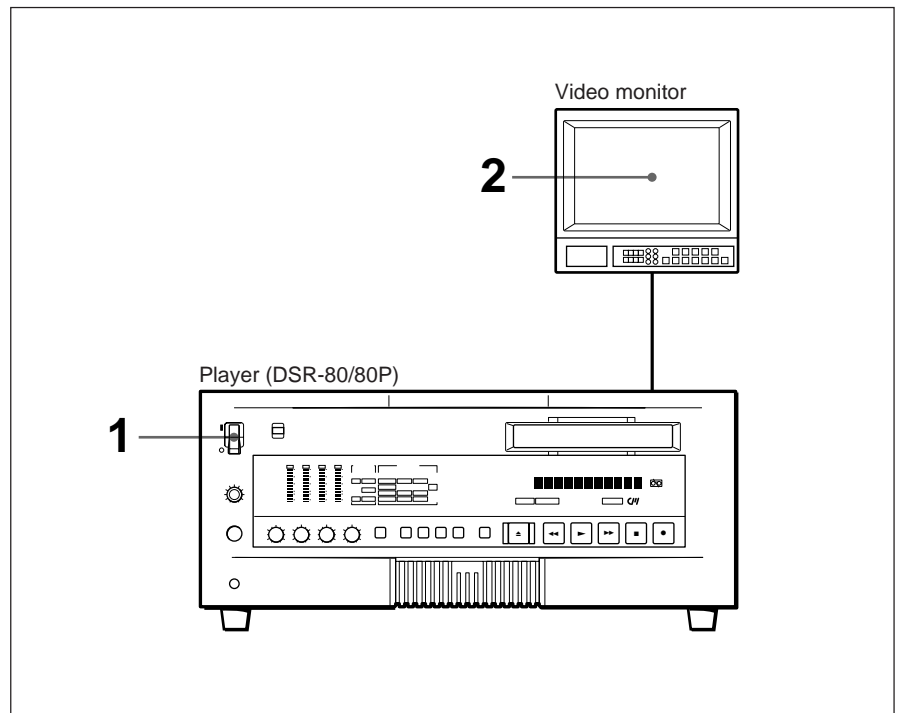

- 1** Power on this unit by pressing on the “I” side of the POWER switch.
- 2** Power on the video monitor and set the monitor’s switches as shown below.

Switch	Setting
75 $\Omega$ termination switch	ON (or attach a 75 $\Omega$ terminator)
Input switch	Set according to the type of input signal from this unit.

## Playback Procedure

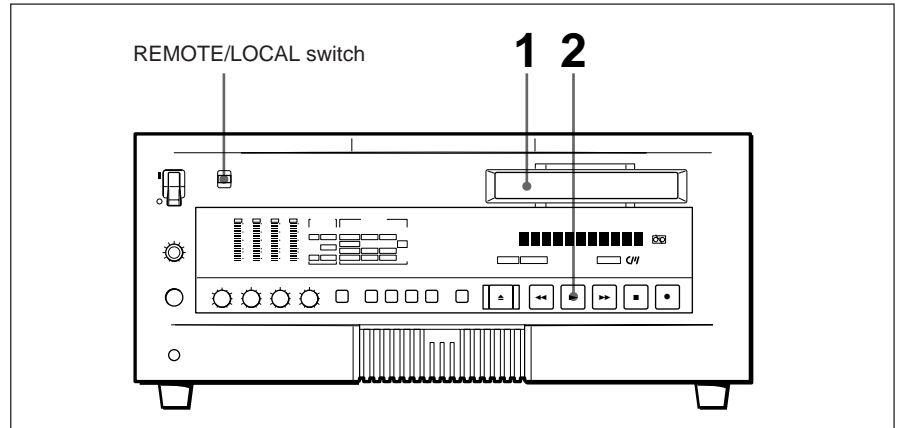

### Note

When controlling this unit from an editing controller, set the REMOTE/LOCAL switch to “REMOTE”. When not, set the switch to “LOCAL”.

### 1 Insert a cassette.

*For details of cassette insertion see page 24, and for usable cassette types see page 22.*

The cassette is automatically drawn into the unit. The STOP button will light, and a few seconds later a still image will appear on the monitor screen.

### 2 Press the PLAY button.

This starts the playback operation. When the tape is played back all the way to the end, the unit automatically rewinds it and then stops.

### If the following indicators light when a cassette is loaded

Indicator :	It means:
Cassette memory indicator C//	The loaded cassette contains a cassette memory.
ClipLink indicator	There is ClipLink log data stored in the cassette memory on the loaded cassette.
NOT EDITABLE indicator	The tape was recorded in the DV format. You can not use it as a recording tape for editing.

### Using this unit to play back a tape recorded on another device

When playing back a tape on this unit that was recorded with a DV format VCR or some DSR-series VCRs, it is not possible to play back the first 10 seconds of the tape, because of the different tape loading mechanism. For any tape to be played back on this unit, it is recommended to make a preliminary recording for about 10 seconds at the beginning.

For this purpose:	Do this:
Stop playback	Press the STOP button. The unit enters stop mode, and will automatically switch to standby off mode after 8 minutes.
Adjust the audio playback level	Use the audio level control on the monitor.
Search while viewing	Press and hold either F FWD or REW button to search at 32 times normal speed in forward or reverse direction. To return to normal playback mode, press the PLAY button.  <b>Note</b> The search picture will not be displayed unless "F. FWD/REW" under the AUTO EE SELECT menu item is set to "PB".
Inhibit the unit from outputting text information (time data, operation mode indications, etc.) to the video monitor.	Change the menu settings. <i>See "CHARA. DISPLAY" (page 43) in Chapter 4 "Menu Settings".</i>
Remove the cassette	Press the EJECT button. After a few seconds, the tape is unwound from the head drum and the cassette is automatically ejected. If a CNT value is shown on the time counter display (assuming the time data type indicator "COUNTER" is lit), the CNT value is reset.
Disable the automatic rewind function	Change the menu settings. <i>See "AUTO REW" (page 42) in Chapter 4 "Menu Settings".</i>
Change the time period before the unit switches to standby off mode from stop mode	Change the menu settings. <i>See "TAPE PROTECTION" (page 46) in Chapter 4 "Menu Settings".</i>

# Setting the Time Data

This unit is provided with the following functions related to time data.

- Display and reset CNT value
- Set, display, record, and play back SMPTE/EBU time code and user bit data

When the unit is equipped with an optional DSBK-130/130P Time Code Input/Output Board, it can output the time code read from the tape as an analog (LTC) signal while in normal-speed playback mode, and receive an external analog time code (LTC) signal.

## Note

Even when the unit is equipped with the DSBK-130/130P, it outputs no signal from the TIME CODE OUT connector unless it is in normal-speed playback mode.

The following explains how to use these functions.

## Displaying Time Data and Operation Mode Indications

Time data and operation mode indications can be displayed on the monitor screen.

Time data can also be displayed in the time counter display on this unit.

### To view time data and operation mode indications on the monitor screen

Select the DISPLAY CONTROL menu item and set “CHARA. DISPLAY” to “ON” (factory default setting).

The time data and the indication of the unit’s current operation mode are superimposed on the composite video signal that is being output from the VIDEO OUT 2 (SUPER) connector, and can be viewed on the monitor screen.

Use the DISPLAY CONTROL menu item to select the information displayed and the character type and position of the indications.

*For details of these menu settings, see Chapter 4 “Menu Settings”.*

When you set “SUB STATUS” under the DISPLAY CONTROL menu item to other than “OFF”, you can also display supplementary status information on the monitor screen about the editing mode settings, recording format of playback tape, and/or time code generator’s operating mode.

*For details of supplementary status information, see “Displaying Supplementary Status Information” (page 55).*

### Monitor screen contents

The contents of the monitor screen are shown below.

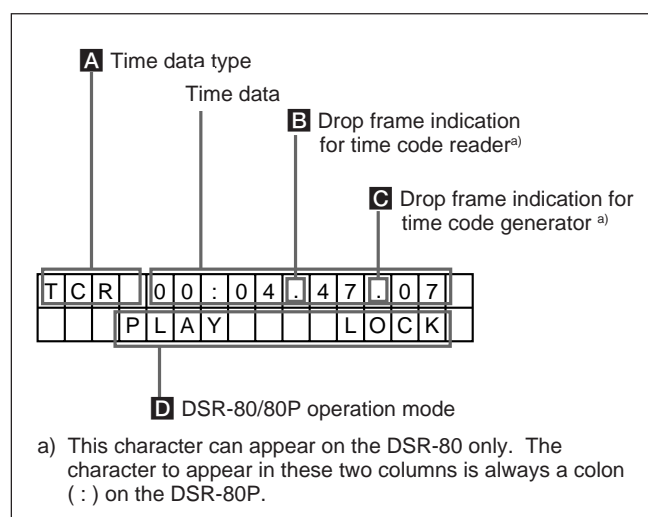

### A Time data type

The following time data type indications are displayed.

Indication	Description
CNT	Count value of the time counter
TCR	Time code data from time code reader (factory default setting)
UBR	User bit data from time code reader
TCG	Time code data from time code generator
UBG	User bit data from time code generator
T*R	Time code data from time code reader. The asterisk indicates an interpolation by the time code reader to make up for the time code data not correctly read from the tape.
U*R	User bit data from the time code reader. The asterisk indicates that last data is retained by the time code reader, as the new data has not been read correctly from the tape.

### B Drop frame indication for time code reader (on DSR-80 only)

.	Drop frame mode (factory default setting)
:	Non-drop frame mode

## Setting the Time Data

### C Drop frame indication for time code generator (on DSR-80 only)

.	Drop frame mode (factory default setting)
:	Non-drop frame mode

### D DSR-80/80P operation modes

Indication	Operation mode
THREADING	Tape is being threaded (this indicator is displayed from the time a cassette is inserted until the tape has been threaded)
UNTHREADING	Tape is being unthreaded (this indicator is displayed from the time the EJECT button is pressed until the cassette is actually ejected)
CASSETTE OUT	No cassette has been loaded
STANDBY OFF	Standby off mode
T. RELEASE	Tension release mode
STOP	Stop mode
F. FWD	Fast forward mode
REW	Rewind mode
PREROLL	Preroll mode
PLAY	Playback mode (servo unlocked)
PLAY LOCK	Playback mode (servo locked)
PLAY PAUSE	Playback pause mode
REC	Recording mode (servo unlocked)
REC LOCK	Recording mode (servo locked)
REC PAUSE	Recording pause mode
EDIT	Edit mode (servo unlocked)
EDIT LOCK	Edit mode (servo locked)
JOG STILL	Still picture playback in jog mode
JOG FWD	Jog forward
JOG REV	Jog reverse
SHUTTLE +2.0	Shuttle mode (playback speed) <sup>a)</sup>
PAUSE	Shuttle playback pause mode

a) "+2.0" in the left box is an example of playback speed indication.

### To display the desired time data in the time counter display

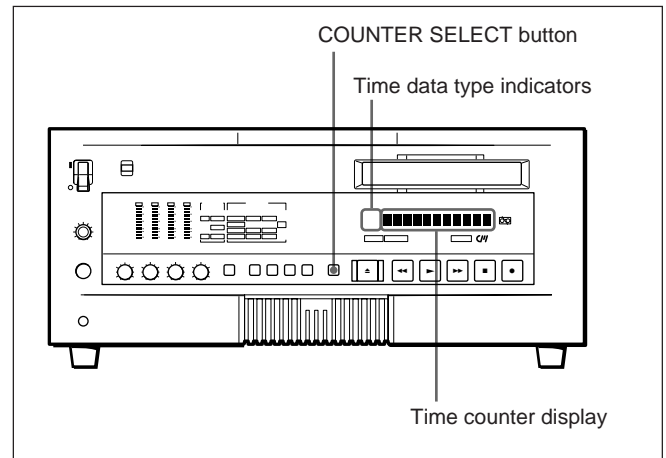

Press the COUNTER SELECT button on the front panel of the unit.

Each press of this button cycles through three options: CNT value, time code, and user bit data. The time data type indicator for each option lights as it is selected.

Time data type indicator	Time data shown in the time counter display
COUNTER	CNT (count value of the time counter)
TC	Time code (if recording, the time code is generated by the internal time code generator; if playing back, the time code is read from the tape)
U-BIT	User bit data (if recording, the user bit data is according to the most recent settings; if playing back, the user bit data is read from the tape)

#### Note

If the REMOTE/LOCAL switch is set to REMOTE, the COUNTER SELECT button does not operate while the tape is moving. In such cases, use the external equipment connected to the REMOTE connector on the rear panel to select the time data.

#### To reset the CNT value

Press the RESET (NO) button on the menu control panel. This resets the CNT value to 0:00:00:00.

#### Note

If during playback the recording on the tape includes discontinuities, the counter may operate incorrectly at the corresponding points.

## Using the Internal Time Code Generator

You can set the time code's initial value before recording the time code generated by the internal time code generator onto a tape. In addition, you can set the time code's user bits to record user bit data such as the date, time, scene number, reel number, or other useful information.

When the unit is equipped with an optional DSBK-130/130P Time Code Input/Output Board, the internal time code generator can be locked to (synchronized with) an external time code.

### To set the time code's initial value and user bit data

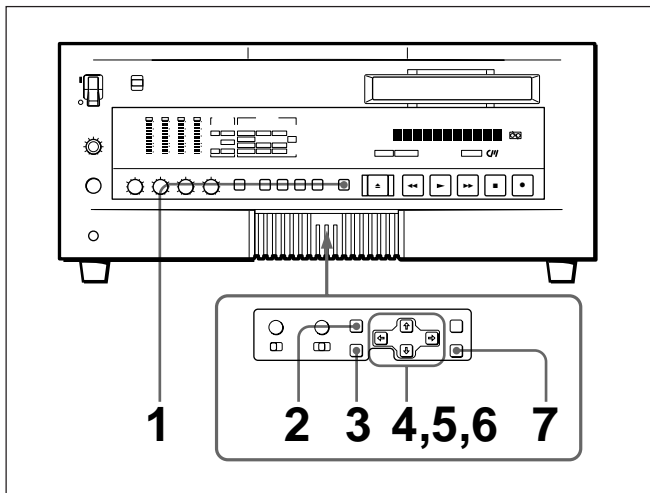

- 1 Press the COUNTER SELECT button to light the time data type indicator "TC" or "U-BIT".  
**TC** : To set the time code's initial value.  
**U-BIT** : To set user bit data

The current time code value or user bit data is shown in the time counter display.

- 2 Set the TIME CODE menu items as shown below.

Menu item	Setting
TC MODE	"INT"
RUN MODE	"FREE RUN" or "REC RUN"
DF MODE (on DSR-80 only)	Usually "DF"

For details of menu settings, see Chapter 4 "Menu Settings".

- 3 Press the TC PRESET button on the menu control panel.

The current setting is shown on the monitor screen and in the time counter display on the unit's front panel. The leftmost digit keeps flashing. One of the following menu screens is displayed on the monitor depending on the setting made in Step 1.

TC PRESET MODE	
TCG 00:00:00:00	
UP	:DATA INCREMENT
DOWN	:DATA DECREMENT
LEFT	:LEFT SHIFT
RIGHT	:RIGHT SHIFT
RESET	:DATA CLEAR
SET	:DATA SET
TC PSET	:ABORT & EXIT

Time code initial value setting screen

UB PRESET MODE	
UBG 00:00:00:00	
UP	:DATA INCREMENT
DOWN	:DATA DECREMENT
LEFT	:LEFT SHIFT
RIGHT	:RIGHT SHIFT
RESET	:DATA CLEAR
SET	:DATA SET
TC PSET	:ABORT & EXIT

User bit setting screen

#### Note

If you press the TC PRESET button while CNT value is being displayed, the message "COUNTER MODE IS SELECTED. SET COUNTER SELECT SWITCH TO TC OR UB" will appear on the monitor screen and "CNT mode!" will appear in the time counter display on the unit's front panel. If this happens, press the COUNTER SELECT button to light the time data type indicator "TC" or "U-BIT".

- 4 Use the  $\leftarrow$  and  $\rightarrow$  buttons to move the flashing digit to the value to be changed.
- 5 Use the  $\uparrow$  and  $\downarrow$  buttons to change the value of the flashing digit.  
Enter hexadecimal values (0 to 9, A to F) when setting user bit data.
- 6 Repeat Steps 4 and 5 until you have set the desired values for all digits.  
To set a value of 00:00:00:00, simply press the RESET (NO) button.

(Continued)

## Setting the Time Data

### 7 Press the SET (YES) button.

The message “NOW SAVING...” appears on the monitor screen, “Saving...” appears in the time counter display, and the new settings are stored in the unit’s memory.

After this saving operation is completed, the monitor screen and the time counter display return to their usual status.

#### Note

The set data may be lost if you power off the unit while the above saving operation is in progress. Wait until the saving operation is completed before powering off.

### Advancement of internal time code generator

The internal time code generator can advance in either of two modes, which can be set via “RUN MODE” under the TIME CODE menu item.

**FREE RUN** : Advancement starts when the data saving operation is completed.

**REC RUN** : Advancement starts when recording starts and stops when recording stops.

### To set the current time as the time code’s initial value

In Step 2 above, set “RUN MODE” under the TIME CODE menu item to “FREE RUN”, then set the current time (format: HH:MM:SS:FF = hours:minutes:seconds:frame number) in Step 3 and subsequent steps.

## Synchronizing Internal and External Time Codes

When the unit is equipped with an optional DSBK-130/130P Time Code Input/Output Board, the internal time code generator can be locked to (synchronized with) an external time code (LTC) that is input to the unit.

### To synchronize the internal time code to external time code

Input an external time code (LTC) signal to the unit’s TIME CODE IN connector, then set “TC MODE” under the TIME CODE menu item to “EXT REGEN”. The internal time code generator locks onto the external time code and starts advancing. Once the internal time code generator has become synchronized in this way, you can disconnect the external time code input and this unit will maintain the synchronized time code.

#### Note

When the selected input mode is “QSDI” (the QSDI indicator is lit in the INPUT MODE display), setting “TC MODE” under the TIME CODE menu item to “EXT REGEN” causes the internal time code generator to automatically synchronize with the external time code input to the unit via the QSDI interface.

Once an external time code signal has been input, the unit’s internal time code advancement mode and frame count mode are automatically set as shown below.

**Advancement mode** : FREE RUN

**Frame count mode** : Same as external time code  
(drop frame or non-drop frame)

### To confirm external synchronization

Press the STOP button to put the unit into stop mode, then press the REC button.

Look at the time counter display and check that the time code value displayed there matches the external time code value.

## Rerecording the Time Code — TC Insert Function

The TC insert function makes it possible to use the internal time code generator to rewrite time code and user bits when the time code recorded on a tape is discontinuous.

You can start recording time code from an initial value which can be set freely. (See page 36.)

### Notes

- Use a tape which is recorded in the DVCAM format. (You cannot use the TC insert function with a tape recorded in DV format.)
- The time code recording starts from the current tape position. Cue the tape up beforehand to the required start position.
- If you use a tape on which ClipLink log data is recorded, the ClipLink log data will be lost.

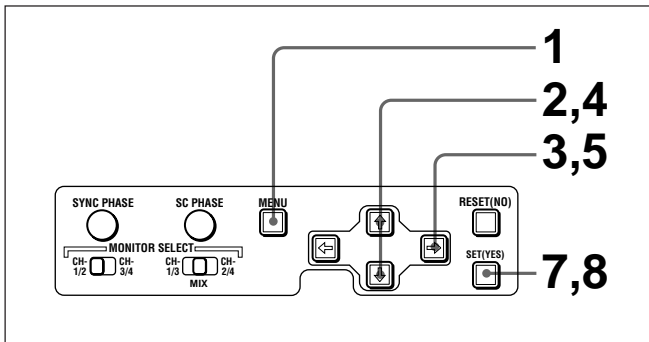

- 1** Press the MENU button on the menu control panel.

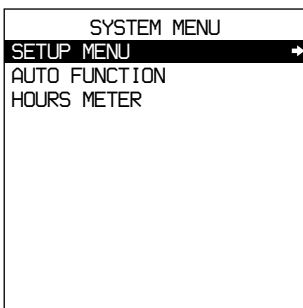

Monitor screen

**Setup menu**

Time counter display

- 2** Press the ↓ button to select “AUTO FUNCTION”.

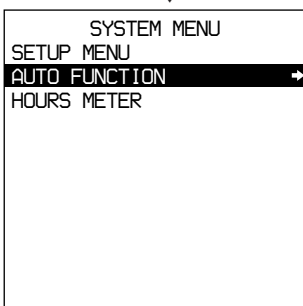

Monitor screen

**Auto func**

Time counter display

- 3** Press the ⇨ button.

This displays the items in the level 1 of the auto mode execution menu.

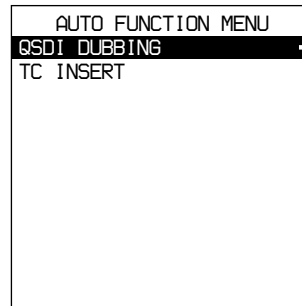

Monitor screen

**QSDI DUB**

Time counter display

- 4** Press the ↓ button to select “TC INSERT”.

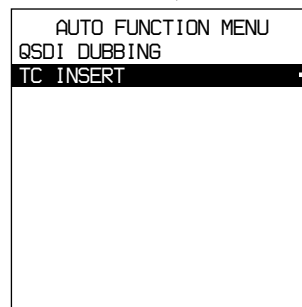

Monitor screen

**TC insert**

Time counter display

- 5** Press the ⇨ button.

The following message appears.

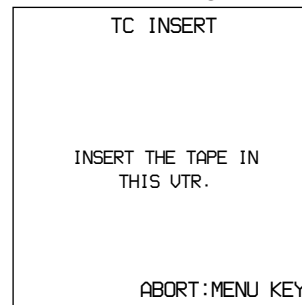

Monitor screen

**Set tape!**

Time counter display

(Continued)

## Setting the Time Data

### 6 Insert the cassette.

A message to confirm the TC insert operation appears.

```
TC INSERT

START TC INSERT?

START: YES KEY
ABORT: MENU KEY
```

Monitor screen

```
TC insert?
```

Time counter display

### To cancel the TC insert operation

Press the MENU button.

### 7 Press the SET (YES) button.

Time code recording starts from the current tape position.

```
TC INSERT

EXECUTING.

TCR 00:00:00:00
UBR 00:00:00:00

ABORT: MENU KEY
```

Monitor screen

```
Executing
```

Time counter display

When the recording ends, the message “TC INSERT COMPLETED. PUSH THE YES BUTTON.” appears on the monitor screen and “COMPLETED” appears in the time counter display.

### 8 Press the SET (YES) button to exit the menu.

# High-Speed and Low-Speed Search: Quickly and Accurately Determining Editing Points

Use the search function to easily locate the desired scene and to quickly and accurately determine edit points.

## Search Operations via External Equipment

You can control the following operation modes of the unit either from an editing controller (such as the ES-7, PVE-500, etc.) connected to the REMOTE connector on the rear panel or from a SIRCS-system remote controller (such as the DSRM-10) connected to the CONTROL S connector on the front panel.

**Shuttle :** Use this mode to view color playback at speeds ranging from 0 to 32 times normal in both directions.

### Note

When controlling the unit from the SVRM-100A for a shuttle-mode search, the maximum possible search speed is 16 times normal in both directions. If you want a faster search than this, hold down the F FWD or REW button. This allows you to view a color playback at 32 times normal in forward or reverse direction.

**Jog :** Use this mode for low-speed search and frame-by-frame search.

**Digital slow :** Use this mode for noise-free color playback at speeds ranging from 0 to  $\frac{1}{5}$  normal in both directions.

**Still :** Use this mode to view a still picture of any field.

**Jog audio :** Use this mode to monitor the audio track at speeds ranging from normal to  $\frac{1}{30}$  normal in both directions.

### Note

When controlling this unit from external equipment, be sure to set the REMOTE/LOCAL switch on the unit's front panel as follows:

External equipment	REMOTE/LOCAL switch setting
Editing controller connected to REMOTE connector	REMOTE
SIRCS-system remote controller connected to CONTROL S connector	LOCAL

*For a description of search operations via external equipment, see the equipment's operating instructions.*

## Search Operations on This Unit

Once "PB" has been set for "F. FWD" and "REW" via AUTO EE SELECT under the OPERATIONAL FUNCTION menu item (factory default setting: "PB"), you can use the F FWD button and REW button for high-speed searching. When using these buttons for high-speed searches, be sure to set the REMOTE/LOCAL switch on the front panel to LOCAL.

### To do a forward high-speed search

Press and hold the F FWD button. While you are holding down the button, you can view the color playback, which is advancing 32 times normal speed.

### To do a reverse high-speed search

Press and hold the REW button. While you are holding down the button, you can view the color playback, which is going at 32 times normal speed in reverse direction.

# Dubbing Signals in QSDI Format — QSDI Dubbing Function

In addition to straightforward tape dubbing, you can also use this unit to dub automatically from the beginning of the tape to the end, through an QSDI interface.

When a tape recorded on a DSR-1/1P Digital Videocassette Recorder or DSR-130/130P Digital Camcorder is dubbed, the ClipLink log data held in the cassette memory is also copied.

## Notes

- Use a tape which is recorded in the DVCAM format. (A tape recorded in DV format cannot be used as a source tape for QSDI dubbing.)
- Regardless of the audio recording mode setting of this unit, dubbing is performed with the original audio recording mode unchanged (two-channel mode (48 kHz) or four-channel mode (32 kHz)).
- Approximately the last 2 minutes of the tape may not be copied because of differences in tape lengths. (If an Index Picture is recorded in this portion, it may also not be copied.)
- A continuous recorded section of approximately 5 seconds is required before the recording start point. It is recommended to record beforehand color bars or a similar signal at the start point of the source tape to be dubbed on this unit.

To carry out QSDI dubbing, this unit must be connected to the REMOTE and QSDI IN/OUT connectors on the DSR-85/85P/80/80P/60/60P.

For details of the connections and switch settings, see the section “Connections for QSDI Dubbing.” (Page 64)

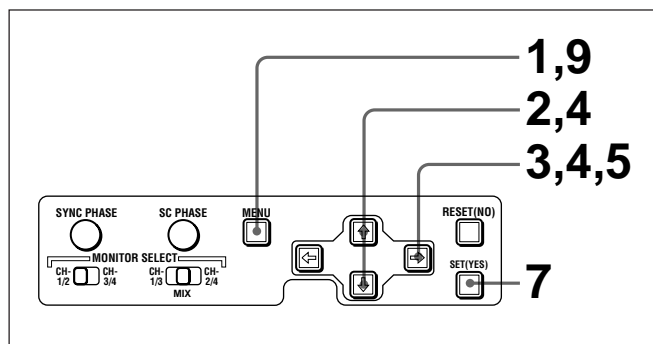

- 1 Press the MENU button on the menu control panel.

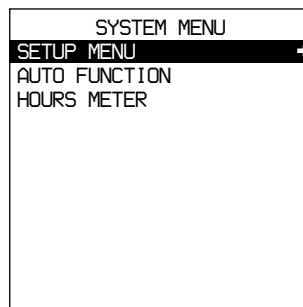

Monitor screen

**Setup menu**

Time counter display

- 2 Press the  $\downarrow$  button to select “AUTO FUNCTION”.

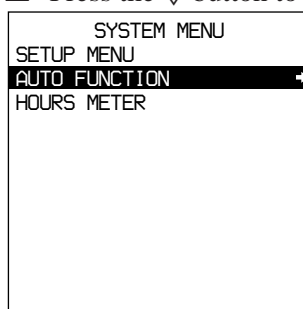

Monitor screen

**Auto func**

Time counter display

- 3 Press the  $\Rightarrow$  button.

This displays the items in the level 1 of the auto mode execution menu.

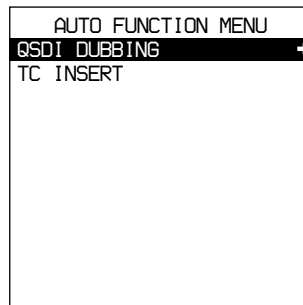

Monitor screen

**QSDI DUB**

Time counter display

- 4 Press the  $\Rightarrow$  button to display the menu level 2 for the item “QSDI DUBBING”, and select the dubbing data with the  $\downarrow$  button.

Example: Selecting “A/V/TC/CM”

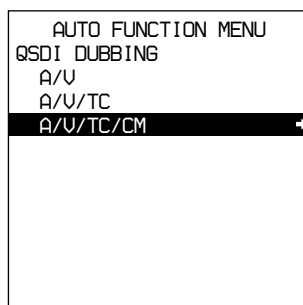

Monitor screen

**>A/V/TC/CM**

Time counter display

## 5 Press the ⇐⇒ button.

The following message appears.

```

QSDI DUBBING
(A/U/TC/CM)

INSERT RECORD TAPE IN
THIS UTR AND SOURCE
TAPE IN THE PLAYER UTR.

ABORT:MENU KEY

```

Monitor screen

```

Set tape!

```

Time counter display

## 6 Insert the source tape in the player, and the recording tape in this unit.

A message to confirm the dubbing operation appears.

```

QSDI DUBBING
(A/U/TC/CM)

START QSDI DUBBING?

START:YES KEY
ABORT:MENU KEY

```

Monitor screen

```

Start dub?

```

Time counter display

### To cancel the dubbing operation

Press the MENU button.

## 7 Press the SET (YES) button.

The tape is automatically wound back to the beginning, and dubbing starts.

```

QSDI DUBBING
(A/U/TC/CM)

EXECUTING.

TCR 00:00:00:00
UBR 00:00:00:00

ABORT:MENU KEY

```

Monitor screen

```

Executing

```

Time counter display

### To end the dubbing operation while it is in progress

Press the STOP button.

When the dubbing is completed, message “COMPLETED” appears on the monitor screen and in the time counter display.

The source tape and recording tape are both automatically rewound to the beginning, and the cassettes ejected. When the cassette is ejected, this unit returns to the state in step 5.

## 8 To continue by dubbing another tape, repeat steps 6 and 7.

## 9 When the dubbing is completed, press the MENU button to exit the menu.

### If the following message appears in step 6 for an A/V/TC/CM dubbing operation

```

QSDI DUBBING
(A/U/TC/CM)

CM MEMORY STORAGE
CAPACITY OF THE RECORD
TAPE IS TOO SMALL.

ABORT:MENU KEY

```

Monitor screen

```

CM capacity!

```

Time counter display

When carrying out A/V/TC/CM dubbing, the contents of the cassette memory of the cassettes inserted in both this unit and the player are checked.

If the cassette memory capacity of the source tape is larger than the cassette memory capacity of the recording tape, the above message appears.

In this case, replace the recording tape by a tape with a larger cassette memory capacity.

## Dubbing Signals in QSDI Format

---

If the following message appears in step 7 for an A/V/TC/CM dubbing operation

```
QSDI DUBBING
(A/V/TC/CM)

QSDI DUBBING IS ABORTED.
EXECUTE CM COPY?

COPY      :YES KEY
NOT COPY:NO  KEY
```

Copy CM?

When carrying out A/V/TC/CM dubbing, if you press the STOP button to stop dubbing in step 7, or if dubbing stops because the source tape is longer than the recording tape, the above message appears, to confirm whether or not to copy the contents of the cassette memory.

To copy the contents of the cassette memory, press the SET (YES) button.

If you do not wish to copy the contents of the cassette memory, press the RESET (NO) button. If you press the RESET (NO) button, however, the contents of the cassette memory may not agree with the material recorded on the tape.

# Menu Organization

As shown in the figure below, the menu system consists of four levels and is functionally divided into three subsystems: the setup menu, the auto mode (AUTO FUNCTION) execution menu and the digital hours meter display menu. This chapter mainly describes the setup menu, showing its contents and how to operate it.

*For details of the auto mode execution menu, see the sections “Dubbing Signals in QSDI Format” (page 38) and “Rerecording the Time Code — TC Insert Function” (page 35).*

*For details of the digital clock display, see the section “Regular Checks” (page 69).*

The items of the setup menu are divided into several functional groups on level 1, and except for the MENU GRADE item the settings themselves are made on level 2 or level 3.

Also, the menu items are divided into two categories according to how frequently they are accessed: the “basic” items, to which frequent access is normally required, and the “enhanced” items, which are less frequently used. In the following figure, the items shown in boldface are basic items, and the other items are enhanced items.

The menu settings are saved in non-volatile memory, which means they are not erased when you power off the unit after executing the setting operation.

Menu organization

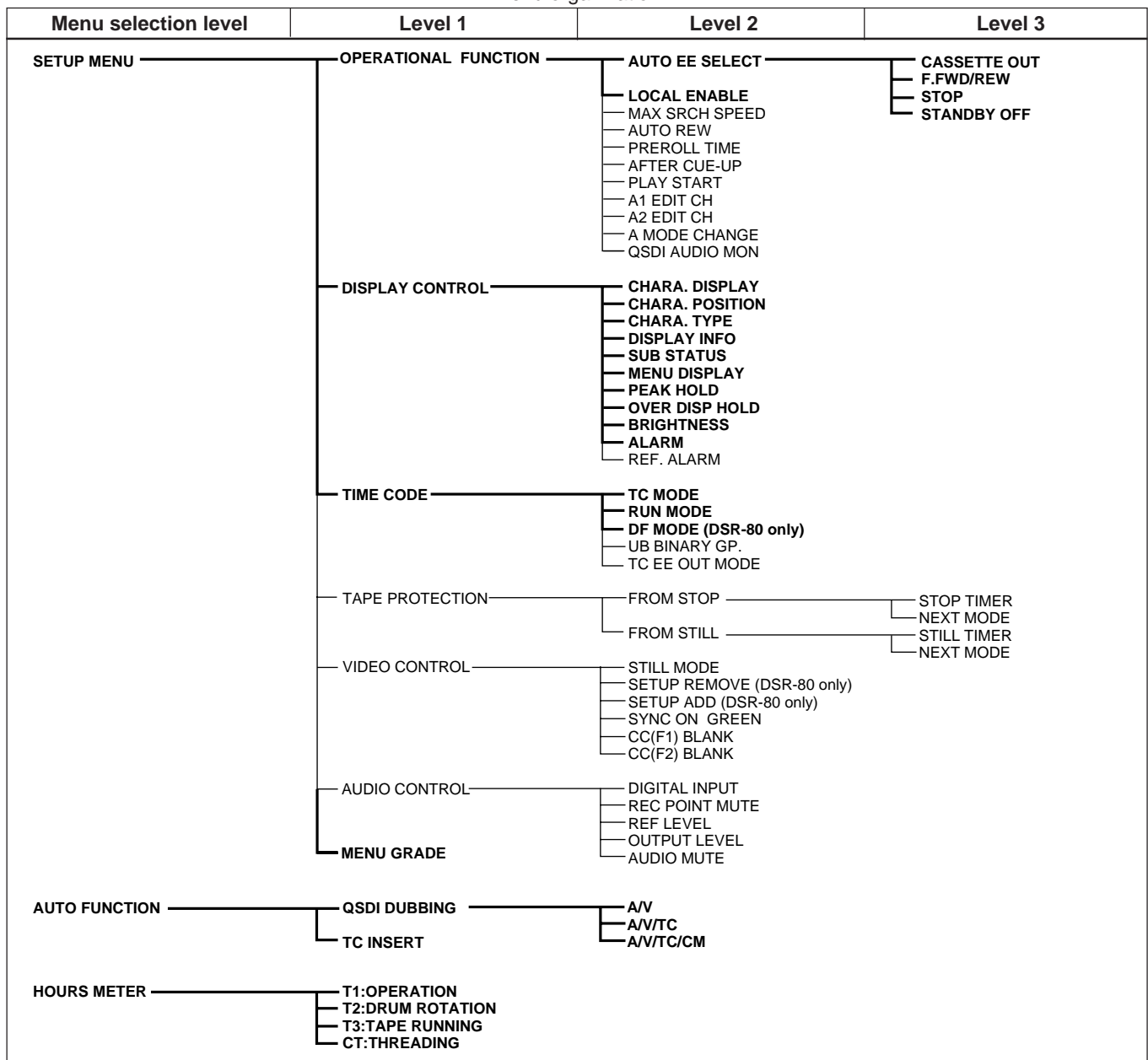

# Menu Contents

## SETUP Menu

The purpose and settings of the setup menu items are described below.

### Indications of menu items and settings

- In the table below entitled “Menu Contents”, the indication of each menu item or setting on the monitor screen is shown first, then the indication of the same item or setting on the time counter display of this unit is shown in square brackets ([ ]). (Examples)

Indication in monitor screen	Indication in time counter display
OPERATIONAL FUNCTION	[Operational]
CASSETTE OUT	[>> Cass. out]
*EE	[>>> EE]

- Settings that have an asterisk in front of them (such as \*EE) are factory default settings.
- On the time counter display, one to three “>” symbols may precede item or setting indications depending on the current menu level. Larger numbers of “>” symbols indicate lower menu levels.

Menu contents

OPERATIONAL FUNCTION [Operational]: Operation settings	Description of settings
AUTO EE SELECT [> Auto EE]: Determine whether the unit enters EE mode or PB mode when audio and video signals from other equipment are input. When this unit is used as the recorder for cut editing, it is possible to output the input audio and video signals to the monitor. The term “EE” mode is used to refer to this feature, which enables the entire editing operation to be carried out with a single monitor.	CASSETTE OUT [>> Cass. out]: Operations when the cassette has been ejected *EE [>>> EE]: Output video and audio signals from other equipment. PB [>>> PB]: Mute video and audio signals.
	F. FWD/REW <sup>a)</sup> [>> F. FWD/REW]: Operations when in fast forward or rewind mode EE [>>> EE]: Output video and audio signals from other equipment. *PB [>>> PB]: Mute video and audio signals. (However, holding down the F FWD or REW button on the front panel makes this setting ineffective temporarily and allows you to perform a picture search at 32 times normal speed in forward or reverse direction.)
	STOP [>> STOP]: Operations when in stop mode EE [>>> EE]: Output video and audio signals from other equipment. *PB [>>> PB]: The unit enters playback mode and outputs a still picture.
	STANDBY OFF [>> STBY OFF]: Operations when in standby off mode EE [>>> EE]: Output video and audio signals from other equipment *PB [>>> PB]: The unit enters playback mode and outputs a still picture.
LOCAL ENABLE [> Local ENA]: Select which of the tape transport control buttons (EJECT, REW, PLAY, F FWD, STOP, REC) operate when the REMOTE/LOCAL switch is set to REMOTE.	ALL DISABLE [>> All DIS]: All of the tape transport control buttons are disabled. *STOP & EJECT [>> STOP & E]: Only the STOP and EJECT buttons are enabled. ALL ENABLE [>> All ENA]: All of the tape transport control buttons are enabled, and settings such as preroll time change or time data display selection are effective.
MAX SRCH SPEED [> Max SRCH]: Set the maximum value for search mode.	× 16 [>> × 16]: Restrict the search speed to the maximum 16 times normal for which the picture can be seen on the monitor. Use this setting when using search mode for cueing. *× 32 [>> × 32]: Restrict the search speed to the maximum 32 times normal for which the picture can be seen on the monitor. Use this setting when using search mode for cueing. × 85 [>> × 85]: Allow searching at up to the maximum tape transport speed of 85 times normal. The picture cannot be seen on the monitor at this speed.
AUTO REW [> AUTO REW]: Determine whether or not to rewind automatically when playback reaches the end of a tape.	*ENABLE [>> ENABLE]: Rewind automatically. DISABLE [>> DISABLE]: Do not rewind automatically.

a) **Note**

Set this item to “PB” when you want to use the F FWD and REW buttons to view playback at 32 times normal

speed. If this item is set to “EE”, holding down the F FWD and REW buttons produces EE pictures.

(Continued)

Menu contents (Continued)

OPERATIONAL FUNCTION [Operational]: Operation settings	Description of settings
PREROLL TIME [> Preroll]: Set the preroll time.	The preroll time can be set in one-second increments to between 0 and 15 seconds (0 SEC [>> 0 SEC] to 15 SEC [>> 15 SEC]). When an editing controller such as the PVE-500 has been connected, this setting is disabled and the editing controller's setting is in effect. Operations such as the preroll time setting and the time data switching operation are also performed on the editing controller. <b>Factory default setting:</b> 5 SEC [>> 5 sec]
AFTER CUE-UP [> After CUE]: Select the operating mode following cue-up.	*STOP [>> STOP]: Stop mode STILL [>> STILL]: Output still pictures in search mode.
PLAY START [> PLAY start]: Set the timing for switching from stop mode to playback mode. In an editing system including an editing controller such as the PVE-500, adjusting this setting so that the delay before switching to playback mode is the same on all the decks of the editing system means that there is no longer a need to synchronize the decks for editing, and the preroll time can be shortened.	16 FRAME DELAY [>> 16 delay] to 4 FRAME DELAY [>> 4 delay]: The larger the numerical value, the longer the delay. By adjusting this setting, it is possible to reduce the phase synchronization time and preroll time during editing. <b>Factory default setting:</b> 5 FRAME DELAY [>> 5 delay] (for DSR-80) or 4 FRAME DELAY [>> 4 delay] (for DSR-80P)
A1 EDIT CH [> A1 Edit CH]: Determine which audio channel the EDIT PRESET command set on an editing controller (such as the PVE-500) for A1 is assigned to.	*CH-1 [>> CH-1]: Assign to channel 1. CH-2 [>> CH-2]: Assign to channel 2. CH-3 [>> CH-3]: Assign to channel 3. CH-1 & CH-2 [>> CH-1&2]: Assign to channel 1 and channel 2.
A2 EDIT CH [> A2 Edit CH]: Determine which audio channel the EDIT PRESET command set on an editing controller (such as the PVE-500) for A2 is assigned to.	*CH-2 [>> CH-2]: Assign to channel 2. CH-3 [>> CH-3]: Assign to channel 3. CH-4 [>> CH-4]: Assign to channel 4. CH-3 & CH-4 [>> CH-3&4]: Assign to channel 3 and channel 4.
A MODE CHANGE [> Aud change]: Determine whether or not to permit an insert editing that uses a different audio recording mode (2- or 4-channel mode) from that which was used for the tape loaded in the recorder.	*OFF [>> OFF]: Do not permit. ON [>> ON]: Permit.
QSDI AUDIO MON [> QSDI A mon]: Determine what type of audio signal to be output as EE audio when the selected input is QSDI.	*QSDI [>> QSDI]: Output the input QSDI audio as it is. ANALOG [>> Analog]: Automatically switch audio input selection and output analog audio. AES/EBU [>> AES/EBU]: Automatically switch audio input selection and output AES/EBU format digital audio. SDI [>> SDI]: Automatically switch audio input selection and output SDI format digital audio.
DISPLAY CONTROL [Display]: Settings related to indications on the monitor and the unit	Description of settings
CHARA. DISPLAY [> Chara disp]: Determine whether or not to output text (such as time code numbers) from the VIDEO OUT 2 (SUPER) connector.	*ON [>> ON]: Output text. OFF [>> OFF]: Do not output text. (In spite of this setting, pressing the MENU button causes menu text to be output.)
CHARA. POSITION [> Chara pos]: Set the position of text superimposed on output from the VIDEO OUT 2 (SUPER) connector to the monitor.	Use ← → ↑ ↓ buttons on the menu control panel to adjust the indication position while watching the monitor screen.  Press the MENU button to confirm the setting and return to the level 1 of the setup menu.

(Continued)

# Menu Contents

## Menu contents (Continued)

DISPLAY CONTROL [Display]: Settings related to indications on the monitor and the unit	Description of settings
CHARA. TYPE [> Chara type]: Set the type of characters in text superimposed on output from the VIDEO OUT 2 (SUPER) connector to the monitor.	Make the following settings while watching the monitor screen. *WHITE (WITH BKGD) [>> White]: White characters on black background BLACK (WITH BKGD) [>> Black]: Black characters on white background WHITE/OUTLINE [>> W/outline]: White characters with black outline BLACK/OUTLINE [>> B/outline]: Black characters with white outline  Press the MENU button to confirm the setting and return to the level 1 of the setup menu.
DISPLAY INFO [> DISP info]: Select information superimposed on output from the VIDEO OUT 2 (SUPER) connector to the monitor.	*TIME DATA & STATUS [>> Time&STA]: Time data and operating mode indications TIME DATA & UB [>> Time&UB]: Time data selected using the COUNTER SELECT button, and user bit data. (When user bit data is selected using the COUNTER SELECT button, user bit data and time code are output.) TIME DATA & CNT [>> Time&CNT]: Time data selected using the COUNTER SELECT button, and CNT value. (When CNT is selected using the COUNTER SELECT button, CNT value and time code are output.) TIME DATA ONLY [>> Time]: Only time data REC DATE & TIME [>> REC Date]: The time data selected with the COUNTER SELECT button is shown on the time counter display, and the date and time of recording are shown on the monitor screen.
SUB STATUS [> Sub status]: Select supplementary status information superimposed on output from the VIDEO OUT 2 (SUPER) connector to the monitor.	*OFF [>> OFF]: Nothing of supplementary status information. EDIT PRESET [>> Edit Pre]: Indications of the editing mode settings made from the connected editing controller. PB FORMAT [>> Format]: Indication of the recording format which was used for the tape being played back. TC MODE [>> TC mode]: Indications of the operating mode of internal time code generator. ALL [>> ALL]: All of the above-mentioned items of supplementary status information.  <i>For details of supplementary status information displayed on the monitor when a setting other than "OFF" is selected, see "Displaying Supplementary Status Information" (page 55).</i>
MENU DISPLAY [> Menu DISP]: Set the type of characters in menu text superimposed on output from the VIDEO OUT 2 (SUPER) connector to the monitor.	Make the following settings while watching the monitor screen. *WHITE [WITH BKGD] [>> White]: White characters on black background BLACK [WITH BKGD] [>> Black]: Black characters on white background WHITE/OUTLINE [>> W/outline]: White characters with black outline BLACK/OUTLINE [>> B/outline]: Black characters with white outline  Press the MENU button to confirm the setting and return to the level 1 of the setup menu.
PEAK HOLD [> Peak hold]: Set the peak hold time for audio level meter.	1.5 SEC [>> 1.5 SEC] to *OFF [>> OFF]: Set the time from zero (OFF) to 1.5 seconds in steps of 0.1 second.

(Continued)

Menu contents (Continued)

DISPLAY CONTROL [Display]: Settings related to indications on the monitor and the unit	Description of settings
OVER DISP HOLD [> Hold OVER]: Determine whether or not to hold the OVER indication display on the audio level meter once the indication lights.	*OFF [>> OFF]: Do not hold the OVER indication display. ON [>> ON (HOLD)]: Hold the OVER indication display.  <b>Note</b> With "ON" selected, once the display is held it will remain held unless you change the setting to "OFF".
BRIGHTNESS [> Brightness]: Set the brightness of front panel indicators.	Set brightness as a percentage of the maximum. *100% [>> 100%] 66% [>> 66%] 33% [>> 33%]
ALARM [> ALARM]: Determine whether alarm messages are issued or not.	*ON [>> ON]: Alarm messages are issued. OFF [>> OFF]: Alarm messages are not issued.
REF. ALARM [> REF ALARM]: Determine whether alarm messages related to reference video signal are issued or not.	ON [>> ON]: Alarm messages are issued. *ON (LIMITED) [>> ON (Limit)]: Alarm messages are issued only during recording mode, EE mode, and while editing. OFF [>> OFF]: Alarm messages are not issued.

TIME CODE [Time code]: Settings related to the time code generator	Description of settings
TC MODE [> TC MODE]: Determine whether to use internal time code (generated by the internal time code generator) or external time code.	*INT PRESET [>> INT]: Use internal time code. EXT REGEN [>> EXT]: Use external time code.  <b>Notes</b> <ul style="list-style-type: none"> <li>To be able to input an LTC signal from external equipment, it is necessary to install the optional DSBK-130/130P Time Code Input/Output Board in this unit.</li> <li>When the selected input mode is "QSDI" (the QSDI indicator is lit in the INPUT MODE display), setting "TC MODE" under the TIME CODE menu item to "EXT REGEN" causes the internal time code generator to automatically synchronize with the external time code input to the unit via the QSDI interface.</li> </ul>
RUN MODE [> RUN mode]: Select the time code generator's advancement (RUN) mode.	*FREE RUN [>> FREE RUN]: Time code generator keeps running. REC RUN [>> REC RUN]: Time code generator only runs while recording.  <b>Note</b> Set to "FREE RUN" when carrying out editing with an editing controller. With the "REC RUN" setting, editing and other operations will not be carried out correctly.
(Only on DSR-80) DF MODE [> DF mode]: Select whether the time code generator and time counter operate in drop frame mode or non-drop frame mode. Normally select drop frame mode, to keep in sync with real time. The non-drop frame mode is useful for example when using computer graphics, and working on a frame count basis.	*ON (DF) [>> ON (DF)]: Drop frame mode OFF (NDF) [>> OFF (NDF)]: Non-drop frame mode
UB BINARY GP. [> UB Binary Gp]: Select the user bit binary group flag of the time code generator  <b>Note</b> When the TC MODE menu item is set to EXT REGEN, the user-bit binary group flag setting follows the setting on the time code input to this unit.	*000: NOT SPECIFIED [>> 000]: Character set not specified 001: ISO CHARACTER [>> 001]: 8-bit characters conforming to ISO 646 and ISO 2022 010: UNASSIGNED-1 [>> 010]: Undefined 011: UNASSIGNED-2 [>> 011]: Undefined 100: UNASSIGNED-3 [>> 100]: Undefined 101: PAGE/LINE [>> 101]: Multiplex 110: UNASSIGNED-4 [>> 110]: Undefined 111: UNASSIGNED-5 [>> 111]: Undefined

(Continued)

# Menu Contents

## Menu contents (Continued)

TIME CODE [Time code]: Settings related to the time code generator	Description of settings
<p>TC EE OUT MODE [&gt;TC out mod]: This only appears when the optional DSBK-130/130P Timecode Input/Output Board is installed.</p> <p>It controls the phase of the LTC signal output when recording timecode and in "STOP REC" mode (forced EE mode).</p>	<p>* MUTE [&gt;&gt;mute]: Output no timecode.</p> <p>THROUGH [&gt;&gt; through]: Output LTC with the phase synchronized to the signal input to the TIME CODE IN connector. Use this mode when the signal input to the VIDEO IN connectors is not synchronized to the reference video signal. (See the example configuration on page 48.)</p> <p>VIDEO INPUT PHASE [&gt;&gt; V input]: Output LTC with the phase synchronized to the input video signal. Use this mode when using the video input in a bridging (loop-through) connection. (See the example configuration on page 48.)</p> <p>VIDEO OUTPUT PHASE [&gt;&gt; V output]: Output LTC with the phase synchronized to the output video signal. Use this mode when using a bridging (loop-through) connection from the output video to the input video. (See the example configuration on page 49.)</p>

TAPE PROTECTION [Tape protect]: Settings related to tape and video head protection		Description of settings
<p>FROM STOP [&gt; From STOP]: Set the time to switch from stop mode to tape protection mode and select the mode for protecting the video heads and video tape.</p>	<p>STOP TIMER [&gt;&gt; STP timer]: Set the time to switch from stop mode to tape protection mode.</p>	<p>30 MIN [&gt;&gt;&gt; 30 min] to 0.5 SEC [&gt;&gt;&gt; 0.5 sec]: Select time from 16 settings ranging from 0.5 seconds to 30 minutes in steps of 0.1 second.</p> <p><b>Factory default setting:</b> 8MIN [&gt;&gt;&gt; 8min]</p>
	<p>NEXT MODE [&gt;&gt;&gt; Next mode]: Select tape protection mode when time set in STOP TIMER setting elapses.</p>	<p>*STANDBY OFF [&gt;&gt;&gt; STANDBY]: Standby off mode</p> <p>TENSION RELEASE [&gt;&gt;&gt; T.RLSE]: The tape tension is released, but the picture can still be seen on the monitor.</p> <p><b>Note</b></p> <p>When the unit is in tension release mode, the head drum is still rotating, so the picture can be output and monitored. That is, it is still in "standby on" mode (i.e. is on standby). Therefore, care should be taken over the setting if it is critically important whether the unit is in "standby on" or "standby off" mode (for example when the unit is used for broadcasting).</p>
<p>FROM STILL [&gt; From STILL]: Set the time to switch from still search mode or playback pause mode to tape protection mode. Also select the type of tape protection mode to follow still search mode when the set time elapses (playback pause mode is always followed by tension release mode).</p>	<p>STILL TIMER [&gt;&gt; STL timer]: Set the time to switch from still search mode or playback pause mode to tape protection mode.</p>	<p>30 MIN [&gt;&gt;&gt; 30 min] to 0.5 SEC [&gt;&gt;&gt; 0.5 sec]: Select time from 16 settings ranging from 0.5 seconds to 30 minutes in steps of 0.1 second.</p> <p><b>Factory default setting:</b> 8MIN [&gt;&gt;&gt; 8min]</p>
	<p>NEXT MODE [&gt;&gt;&gt; Next mode]: Select the type of tape protection mode to follow still search mode when the time set in "STILL TIMER" elapses.</p>	<p>*STEP FWD [&gt;&gt;&gt; Step]: The tape is advanced at 1/30 normal speed for 2 seconds.</p> <p>STANDBY OFF [&gt;&gt;&gt; STANDBY]: Standby off mode</p> <p>TENSION RELEASE [&gt;&gt;&gt; T.RLSE]: The tape tension is released, but the picture can still be seen on the monitor.</p> <p><b>Note</b></p> <p>When the unit is in step forward or tension release mode, the head drum is still rotating, so the picture can be output and monitored. That is, it is still in "standby on" mode (i.e. is on standby). Therefore, care should be taken over the setting if it is critically important whether the unit is in "standby on" or "standby off" mode (for example when the unit is used for broadcasting).</p>

Menu contents (Continued)

<b>VIDEO CONTROL [Video]: Settings related to video control</b>	<b>Description of setting</b>
STILL MODE [> STILL mod]: Determine whether the image of a whole frame or a field is output in still playback mode.	FRAME STILL [>> Frame]: Output the image of a whole frame. *FIELD 1 STILL [>> Field 1]: Output the image of field 1 only. FIELD 2 STILL [>> Field 2]: Output the image of field 2 only.
(Only on DSR-80) SETUP REMOVE [> Setup rmv]: Determine whether or not to remove black setup from analog video input signals.	*OFF [>> OFF]: Do not remove black setup. ON [>> ON]: Remove black setup.
(Only on DSR-80) SETUP ADD [> Setup add]: Determine whether or not to add black setup to analog video output signals.	*OFF [>> OFF]: Do not add black setup. ON [>> ON]: Add black setup.
SYNC ON GREEN: When outputting RGB signals from the COMPONENT VIDEO Y, R-Y, and B-Y/RGB OUT connectors, select whether or not to include a sync signal in the green signal.	*ON [>>ON]: Include a sync signal (use the RGB three-wire mode). OFF [>>OFF]: Do not include a sync signal. (Use the RGB four-wire mode, and output the sync signal from the REF VIDEO OUT connector.)
CC(F1)BLANK [>CC1 blank]: Select whether or not to blank the closed caption first field signal.	*OFF [>>OFF]: Do not blank. ON [>>ON]: Blank.
CC(F2)BLANK [>CC2 blank]: Select whether or not to blank the closed caption second field signal.	*OFF [>>OFF]: Do not blank. ON [>>ON]: Blank.

<b>AUDIO CONTROL [Audio]: Settings related to audio control</b>	<b>Description of setting</b>
DIGITAL INPUT [> Digi. Input]: Enable or disable the AUDIO INPUT LEVEL control knobs to work for AES/EBU, SDI, or QSDI format digital audio input.	*VARIABLE [>> Variable]: Enable the control knobs. BYPASS [>> Bypass]: Disable the control knobs.
REC POINT MUTE [> REC pt mute]: Determine whether or not to mute audio at the joints of recordings.	*OFF [>> OFF]: Mute. ON [>> ON]: Do not mute.
REF LEVEL [> REF Level]: Select reference audio level.	Select the level from among the following three: -12dB [>> -12dB], -18dB [>> -18dB], and -20dB [>> -20dB] <b>Factory default setting:</b> -20 dB (DSR-80), -18 dB (DSR-80P)
OUTPUT LEVEL [>OUT Level]: Select the audio output reference level.	Select the level from the following three settings: *+4dB [>>+4dB], 0dB [>>0dB], -6dB [>>-6dB],
AUDIO MUTE [>Audio mute]: Select whether or not to mute the output until the audio signal has stabilized, in the transition from still/search mode to playback.	ON [>>ON]: Mute. *OFF [>>OFF]: Do not mute. (This reduces the time delay until the audio signal is output.)  <b>Notes</b> <ul style="list-style-type: none"> <li>• In the transition from the stop mode to playback, muting is always applied until the audio signal has stabilized.</li> <li>• The search speeds at which an audio signal can be output vary from model to model.</li> </ul>

<b>MENU GRADE [Menu grade]: Selection of menu items to be displayed</b>	<b>Description of settings</b>
Determine whether to display basic items only or both basic and enhanced items on the monitor screen and on the time counter display when using the menu.	*BASIC [> Basic]: Display basic items only. ENHANCED [> Enhanced]: Display both basic and enhanced items.

### TC EE OUT MODE settings

Use the following as reference information when setting “TC EE OUT MODE” (see page 46).

#### • THROUGH mode

In this mode, the LTC signal is output with the phase synchronized to the input timecode signal, and is appropriate when recording signals from multiple devices on a number of VCRs.

When the camcorder is in genlock mode the timecode precision is  $\pm 0$  frames, and when not in genlock mode is  $\pm 1$  frame.

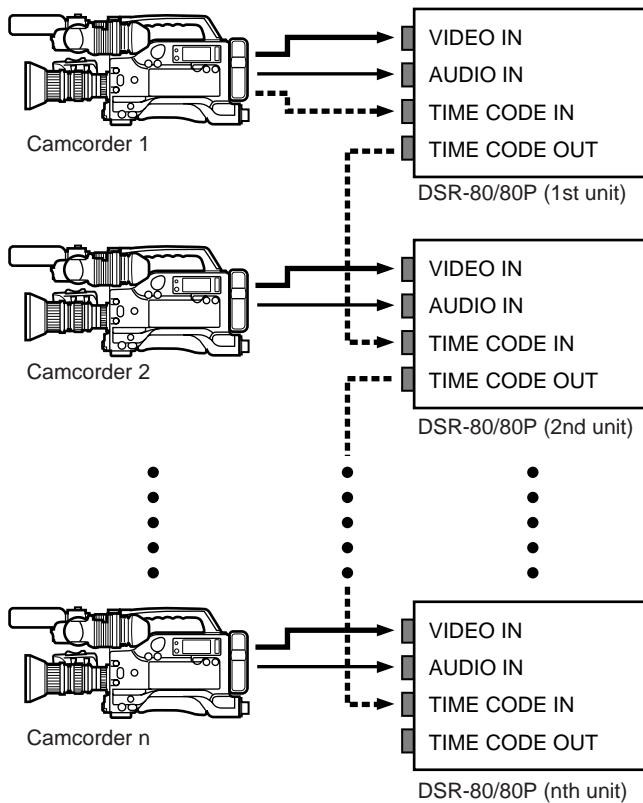

Composite video or S-video signal  
 Audio signal  
 Timecode signal

#### • VIDEO INPUT PHASE mode

The timecode output signal is synchronized to the input video signal.

This mode is appropriate when the output from a single device is recorded on a number of VCRs. The connections are loop-through connections.

In this mode, the same timecode is recorded on all of the VCRs 1 to n.

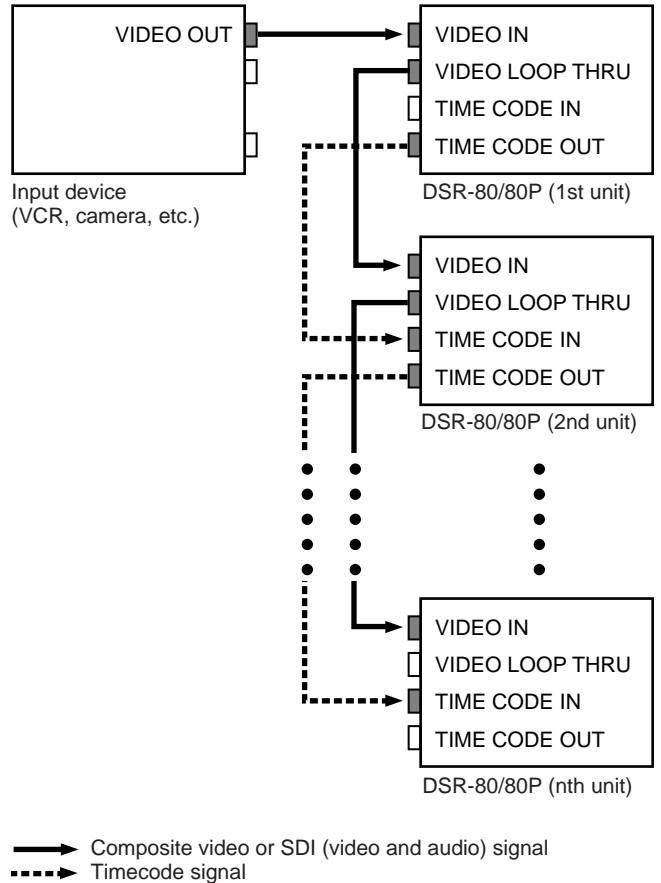

Composite video or SDI (video and audio) signal  
 Timecode signal

• **VIDEO OUTPUT PHASE mode**

The timecode output signal is synchronized to the output video signal.

This mode is appropriate when the output from a single device is output to a number of VCRs with separate cables for video, audio, and timecode.

In this mode, the same timecode is recorded on all of the VCRs 1 to n.

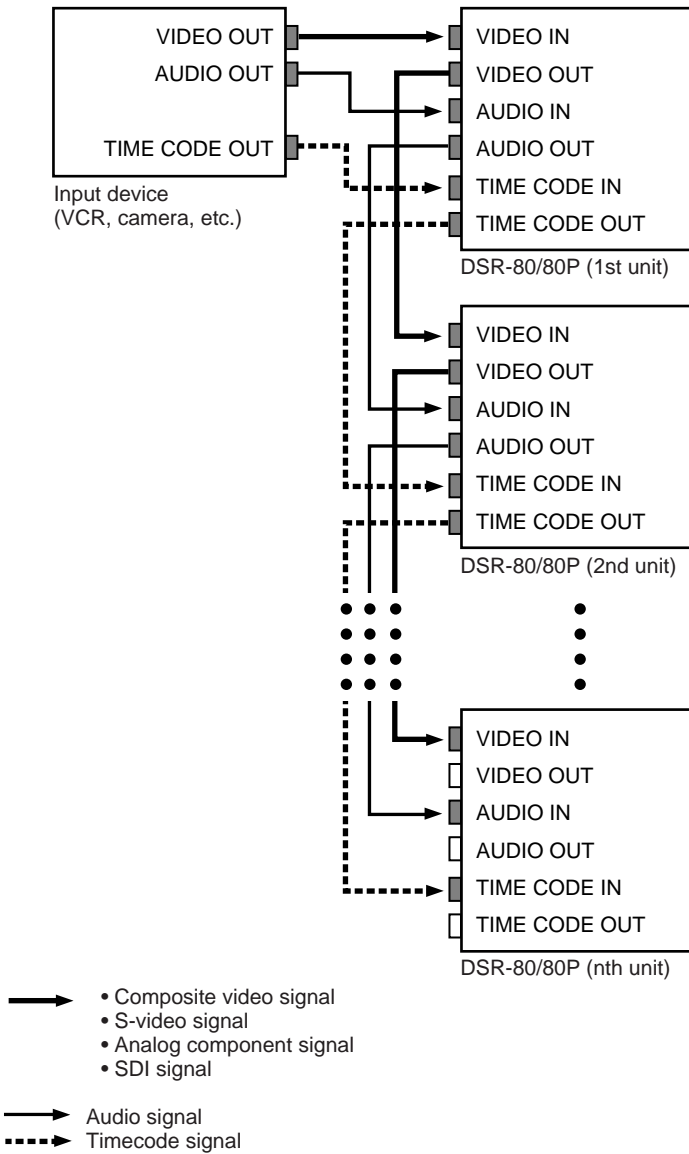

# Menu Contents

## Auto mode (AUTO FUNCTION) execution menu

The following table shows the purpose and function of the items in the auto mode execution menu.

*For details of the use of individual items, see the sections “Dubbing Signals in QSDI Format” (page 38) and “Rerecording the Time Code — TC Insert Function” (page 35).*

Menu contents

QSDI DUBBING [QSDI dub]: Selection of data for QSDI dubbing	Description of setting
For dubbing through the QSDI interface, select data that the dubbing applies to.	A/V [> A/V]: Dub the audio and video. A/V/TC [> A/V/TC]: Dub the audio, video, and time code. A/V/TC/CM [> A/V/TC/CM]: Dub the audio, video, time code, and cassette memory contents.  <b>Note</b> When “A/V” is selected, the time code recorded follows the setting of the TIME CODE item in the setup menu.
TC INSERT [TC insert]: Time code rewriting	Description of setting
Rewrite the time code from an initial value which can be set freely.	—

# Changing Menu Settings

This section explains how to change menu settings.

## Buttons Used to Change Settings

Use the following buttons on the menu control panel to change the menu settings.

Menu control buttons	Functions
MENU button	<ul style="list-style-type: none"> <li>• Opens the menu and launches menu control mode.</li> <li>• Closes the menu and exits menu control mode.</li> </ul>
↑ and ↓ buttons	<p>These buttons move the highlighted cursor up and down within the current level to select an item or setting. Hold down one of these buttons to make the highlighted cursor move continuously.</p>
⇐ and ⇒ buttons	<ul style="list-style-type: none"> <li>• Press the ⇒ button to go down one level.</li> <li>• Press the ⇐ button to go up one level.</li> </ul> <p>Hold down one of these buttons to make the highlighted cursor move continuously.</p>
RESET (NO) button	<ul style="list-style-type: none"> <li>• Returns the setting to the factory default setting.</li> <li>• Sends a negative response to prompts on the monitor screen.</li> </ul>
SET (YES) button	<ul style="list-style-type: none"> <li>• Saves the new setting in memory.</li> <li>• Sends a positive response to prompts on the monitor screen.</li> </ul>

## Changing the Settings of Basic Items

The factory default setting is to display only basic items. To change the settings of basic items proceed as follows.

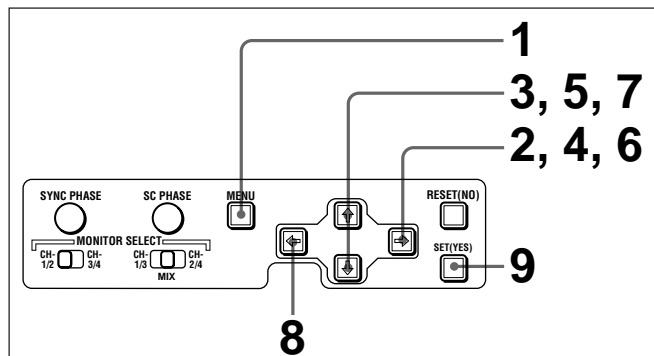

**1** Press the MENU button on the menu control panel.

The menu selection level display appears on the monitor, with “SETUP MENU” selected (shown in reverse video).

The time counter display of this unit shows only the currently selected item. When the item name is long, it is abbreviated.

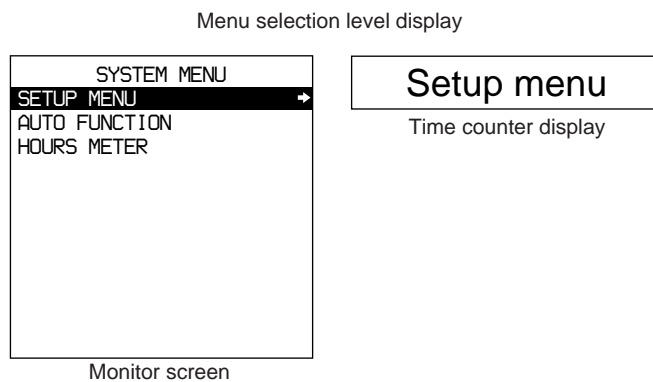

**2** Press the ⇒ button.

This displays all items in the menu level 1.

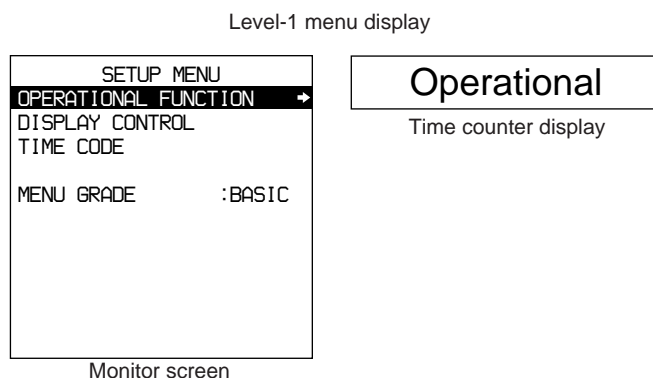

**3** Press the ↓ or ↑ button, to select the required item.

Example: Display when “DISPLAY CONTROL” is selected

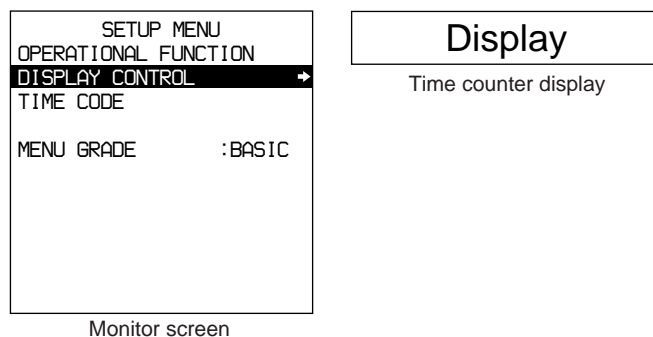

(Continued)

# Changing Menu Settings

**4** Press the ⇨ button.

This displays the menu level 2 for the menu item selected in step 3.

Example: Level-2 display for "DISPLAY CONTROL"

The diagram shows two screens. On the left, the 'Monitor screen' displays the 'SETUP MENU' with 'DISPLAY CONTROL' selected. The level-2 menu items are: CHARA.DISPLAY :ON, CHARA.POSITION, CHARA.TYPE :WHITE, DISPLAY INFO :T&STA, SUB STATUS :OFF, MENU DISPLAY :WHITE, PEAK HOLD :OFF, OVER DISP HOLD :OFF, BRIGHTNESS :100%, and ALARM :ON. An arrow labeled 'Current settings' points to the 'BRIGHTNESS :100%' line. On the right, the 'Time counter display' shows '> Chara disp'.

**5** Press the ↓ or ↑ button to select the item whose setting you wish to change. For menu items with a level 3, press the ⇨ button to go to the level 3, then press the ↓ or ↑ button to select the item whose setting you wish to change.

Example: Display when "BRIGHTNESS" is selected

The diagram shows two screens. On the left, the 'Monitor screen' displays the 'SETUP MENU' with 'BRIGHTNESS :100%' selected. The level-3 menu items are: \* 100%, 66%, and 33%. On the right, the 'Time counter display' shows '> Brightness'.

**6** Press the ⇨ button.

This displays all possible settings for the item selected in step 5.

The diagram shows two screens. On the left, the 'Monitor screen' displays the 'SETUP MENU' with 'BRIGHTNESS :100%' selected. The level-3 menu items are: \* 100%, 66%, and 33%. On the right, the 'Time counter display' shows '>> 100%'.

**7** Press the ↓ or ↑ button to change the setting of the item.

The diagram shows two screens. On the left, the 'Monitor screen' displays the 'SETUP MENU' with 'BRIGHTNESS :33%' selected. The level-3 menu items are: \* 100%, 66%, and 33%. On the right, the 'Time counter display' shows '>> 33%'.

**8** To change other settings, press the ⇐ button to return to the previous screen, then repeat steps 5 to 7 as required.

**9** When you have completed the settings, press the SET (YES) button.

The message "NOW SAVING..." appears on the monitor screen, and "Saving..." appears in the time counter display, while the new settings are saved in the unit's memory. When the saving operation is completed, the monitor screen and time counter display return to their normal indications.

### Notes

- If you power off the unit before setting operation is completed, settings will be lost. Wait until the saving is completed before powering off the unit.
- If instead of pressing the SET (YES) button you press the MENU button, the new settings are not saved. The message "ABORT !" appears both on the monitor screen and in the time counter display for 0.5 seconds, and the system forcibly exits the menus. To change more than one setting, be sure after making the settings to press the SET (YES) button.

## Meanings of indications on the monitor screen

On-screen indication	Meaning
Right-pointing arrow at the right of a menu item (See step 1 on page 51)	Pressing the $\Rightarrow$ button switches to the next lower menu level or to a setting selection screen.
Left-pointing arrow at the left of a menu item (See step 4 on page 52.)	Pressing the $\Leftarrow$ button returns to the previous (higher) menu level.
Character string at the right of a menu item (See step 4 on page 52.)	Current setting of the menu item. When shown with a colon: the current setting is the same as the factory default. When shown with a raised dot: the current setting is different from the factory default. (See step 2 on this page.)
An asterisk by a complete list of settings (See step 6 on page 52)	Factory default setting.

## Displaying Enhanced Items

The factory default setting is not to display enhanced items.

To display enhanced items, use the procedure in the previous section, “Changing the Settings of Basic Items,” to set the item “MENU GRADE” to “ENHANCED.” (In step 3 on page 51 select “MENU GRADE”, and select “ENHANCED,” then press the SET (YES) button to save the setting in memory.)

Once the menu item “MENU GRADE” is set to “ENHANCED,” when you press the MENU button and the  $\Rightarrow$  button to display the SETUP menu, all basic and enhanced items in the menu level 1 appear.

## Changing the Settings of Enhanced Items

To change the settings of enhanced items, first carry out the procedure in the previous section “Displaying Enhanced Items,” then proceed as follows.

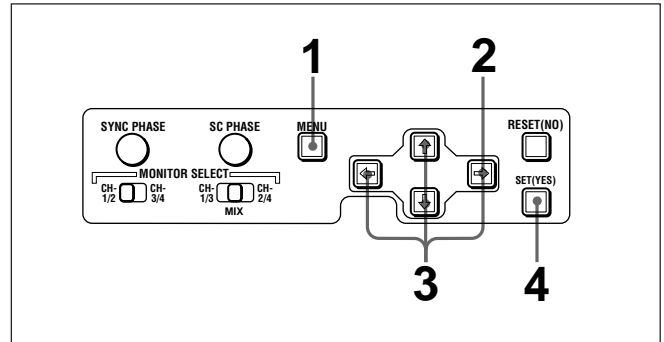

- 1 Press the MENU button on the menu control panel.

The menu selection level display appears on the monitor.

- 2 Press the  $\Rightarrow$  button.

This displays all basic and enhanced items in the menu level 1.

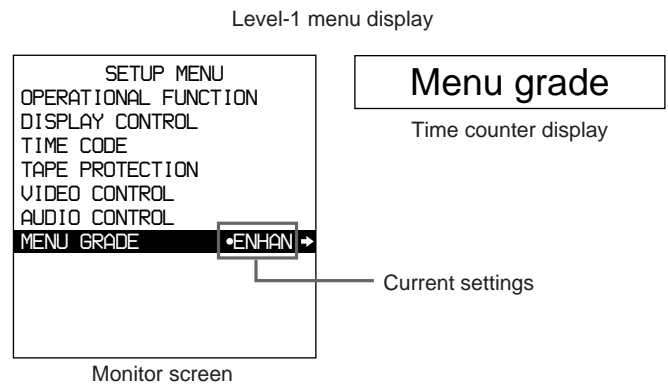

- 3 Follow the same procedure as in steps 3 to 8 of the procedure in the section “Changing the Settings of Basic Items,” using the arrow buttons to select an item and change its setting.

(Continued)

## Changing Menu Settings

- 4 When you have completed the settings, press the SET (YES) button.

The message “NOW SAVING...” appears on the monitor screen, and “Saving...” appears in the time counter display, while the new settings are saved in the unit’s memory.

When the saving operation is completed, the monitor screen and time counter display return to their normal indications.

### Returning Menu Settings to Their Factory Defaults

After making menu setting changes, to return settings to their factory defaults, use the following procedure.

#### To return a particular setting to its factory default

In the display for changing the setting in question, press the RESET (NO) button.

Carry out the procedure in the section “Changing the Settings of Basic Items” (page 51) up to step 6, then with the list of the setting displayed (in the example, if the setting has been changed it will be “66%” or “33%”) press the RESET (NO) button, to return the setting to its factory default of “100%”.

#### To return all settings to their factory defaults

- 1 Press the MENU button on the menu control panel, to display the menu selection.
- 2 Press the  $\Rightarrow$  button, to display level 1 of the setup menu.
- 3 Press the RESET (NO) button.

A message appears, to confirm whether or not you wish to return all settings to their factory defaults.

<b>Monitor screen message</b>	“INITIALIZE ALL ITEMS TO FACTORY PRESET VALUES?”
<b>Message in the time counter display</b>	“Init setup?”

- 4 Press the SET (YES) button.

The message “NOW SAVING...” appears on the monitor screen, and “Saving...” appears in the time counter display, while the settings of all items are returned to their factory defaults, and these factory defaults are saved in the unit’s memory.

#### Note

If you power off the unit while settings are being saved, settings may not be correctly returned to their factory defaults. Wait until the saving is completed before powering off the unit.

#### To abandon the resetting operation

Instead of pressing the SET (YES) button, press the RESET (NO) button. The display returns to menu level 1, leaving the settings unchanged.

# Displaying Supplementary Status Information

When you set “SUB STATUS” under the DISPLAY CONTROL menu item to other than “OFF”, you can view supplementary status information on the monitor screen below the operating mode display area.

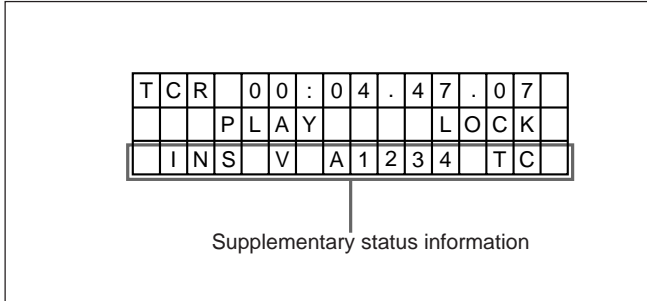

The following items of supplementary status information are displayed depending on the setting of “SUB STATUS”.

Setting of “SUB STATUS”	Items of supplementary information displayed
EDIT PRESET	Editing mode settings made on the editing controller
PB FORMAT	Recording format of the tape being played back
TC MODE	Operating mode of the internal time code generator
ALL	All of the above items

The following tables show the on-screen indications of supplementary information and their meaning. In each table, the indications given in brackets such as [ASM] are the indications displayed when “SUB STATUS” is set to “ALL”. (For the display format when “ALL” is selected, see the next paragraph.)

## When “SUB STATUS” is set to “EDIT PRESET”:

On-screen indication	Meaning
ASM [ASM]	Assemble editing mode
INS V A1234 TC [V1234T]	INS: Insert editing mode V A1234 TC: Channel or signal selected for insert editing V: Video A1234: Audio 1, 2, 3, 4 TC: Time code

## When “SUB STATUS” is set to “PB FORMAT”:

On-screen indication	Meaning
DVCAM [DC]	DVCAM format
DV [D]	DV format (SP mode)
DV(LP) [D]	DV format (LP mode)

## When “SUB STATUS” is set to “TC MODE”:

On-screen indication	Meaning
INT PRESET FREE [IP F]	The internal time code generator is operating in FREE RUN mode.
INT PRESET REC [IP R]	The internal time code generator is operating in REC RUN mode.
EXT LTC-T&U [ELTU]	The internal time code generator is in synchronization with external time code (LTC) input to the unit via optional DSBK-130/130P board and is generating the same time code value and user bit value as those of the external time code.
EXT QSDI-T&U [EQTU]	The internal time code generator is in synchronization with external time code input to the unit via QSDI interface and is generating the same time code value and user bit value as those of the external time code.

## Display format of supplementary status information when “SUB STATUS” is set to “ALL”

All items of supplementary status information are displayed in the order shown below.

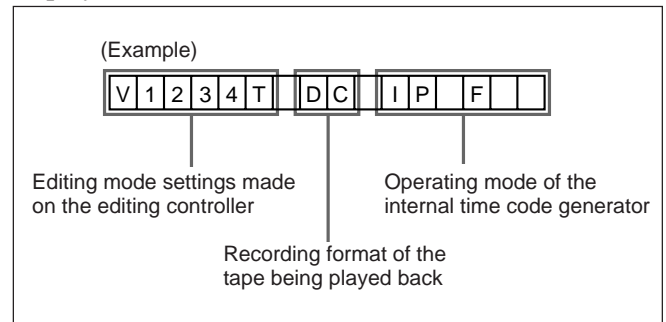



# Connections for a Digital Non-Linear Editing System

This unit can be connected to an ES-7 EditStation to configure a digital non-linear editing system. If you use the QSDI interface, you can transfer video, audio, time code, and other compressed data between this unit and the ES-7. The unit supports ClipLink functions, enabling index pictures recorded on tape and ClipLink log data stored in cassette memory to be transferred to the ES-7 in an instant.

For a general description of ClipLink functions, refer to "ClipLink™ Guide" supplied with the unit.

The following figure shows a connection diagram for non-linear editing system in which this unit serves as the recorder.

For connections of the ES-7 and its peripheral devices such as the ESBK-7011 Control Panel, the ESBK-7045 Disk Unit, etc., refer to your ES-7 Operating Instructions.

**Note**

The example connections shown in this chapter assume that DSR-85/85P, DSR-80/80P, and DSR-60/60P units have DSBK-100/110/120/130 (or DSBK-100P/110P/120P/130P) option boards installed.

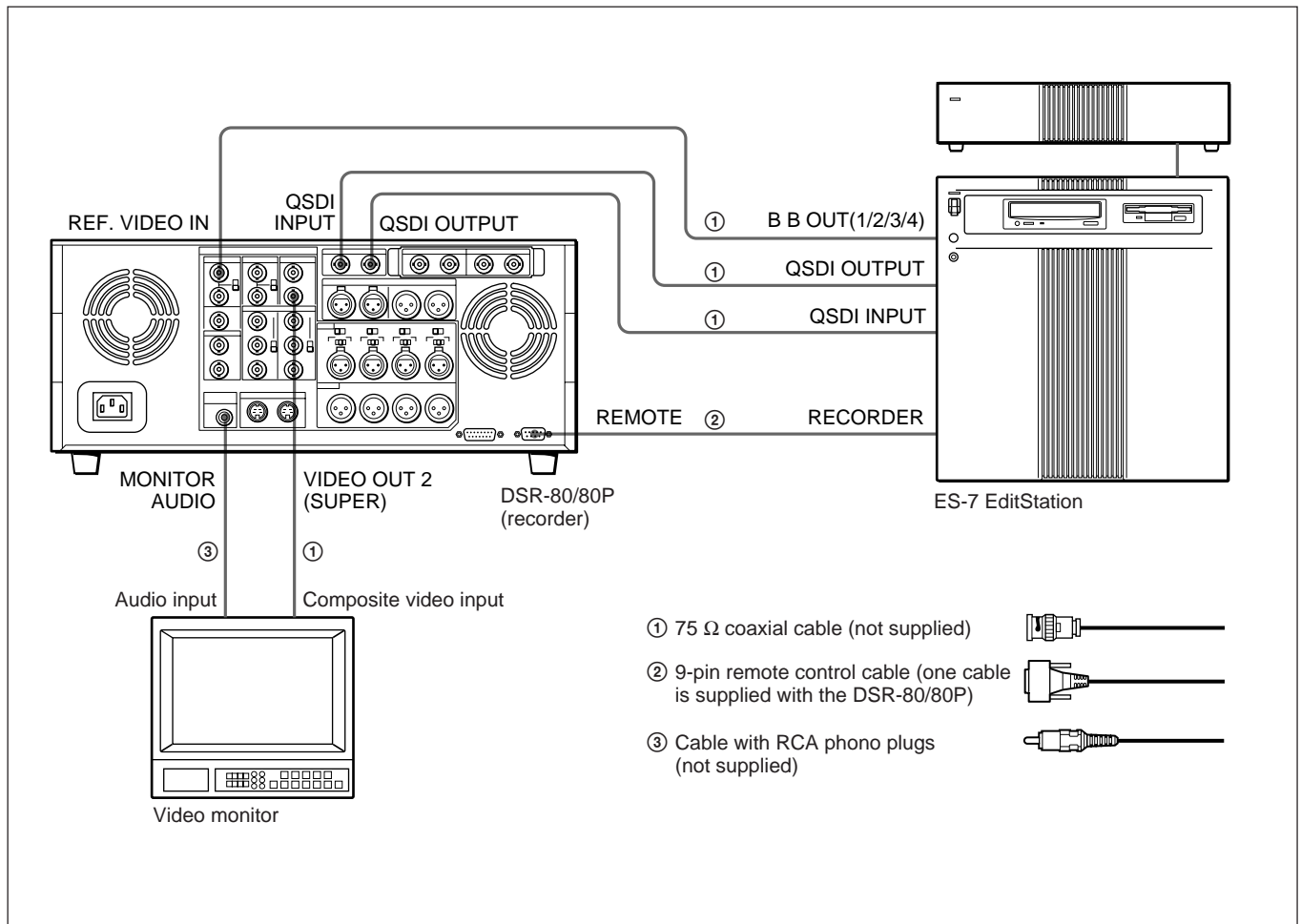

Settings on the DSR-80/80P

Switch	Setting
REMOTE/LOCAL	REMOTE
REF. VIDEO IN 75Ω termination	ON

For details of video/audio input and audio mode settings, see "Settings for Recording" (page 19).

# Connections for a Cut Editing System

The following figure shows a cut editing system configuration that includes two DSR-80/80Ps to serve as the player and recorder.

For details of connecting devices other than the DSR-80/80Ps, refer to the instruction manual for each device.

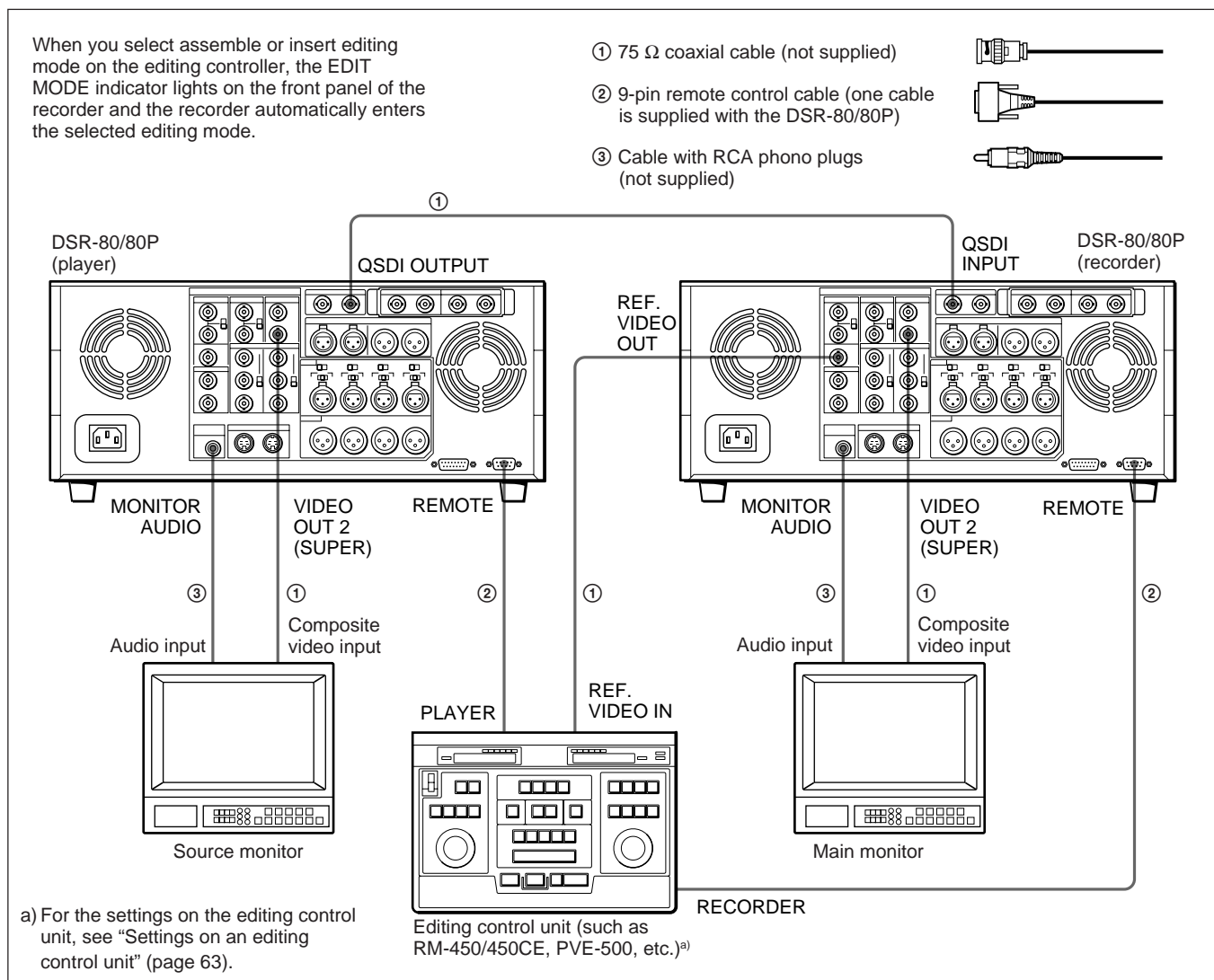

Settings on the DSR-80/80Ps (recorder and player)

Switch	Recorder	Player
REMOTE/LOCAL	REMOTE	REMOTE

For details of the video/audio input and audio mode settings for the recorder, see "Settings for Recording" (page 19).

**Note**

Jog audio playback by the player can only be monitored on the player itself and its monitor. This monitoring cannot be done on the recorder even when it is in EE mode.

## About reference video signals

In order to provide stable video and audio signals for analog editing, it is necessary for the built-in time base corrector (TBC) to operate correctly. To ensure this, input a reference video signal synchronized with the video signal to the REF. VIDEO IN connector and set the REF. VIDEO IN 75 Ω termination switch to ON.

# Connections for an A/B Roll Editing System

The following is an example configuration of A/B roll editing system using the DSR-80/80P.

In this configuration, the recorder is a DSR-80/80P, player 1 is a DSR-60/60P, and player 2 is an analog Betacam UVW-1600/1600P Videocassette Player. To create a final tape (a tape that contains a completely packaged program) in Betacam format, you can use a

Betacam VCR such as the UVW-1800/1800P as the recorder.

The purpose of the following figure is to clearly indicate the flow of signals among the component devices in this system. The specific connections and DSR-80/80P settings for this system are described beginning on the next page.

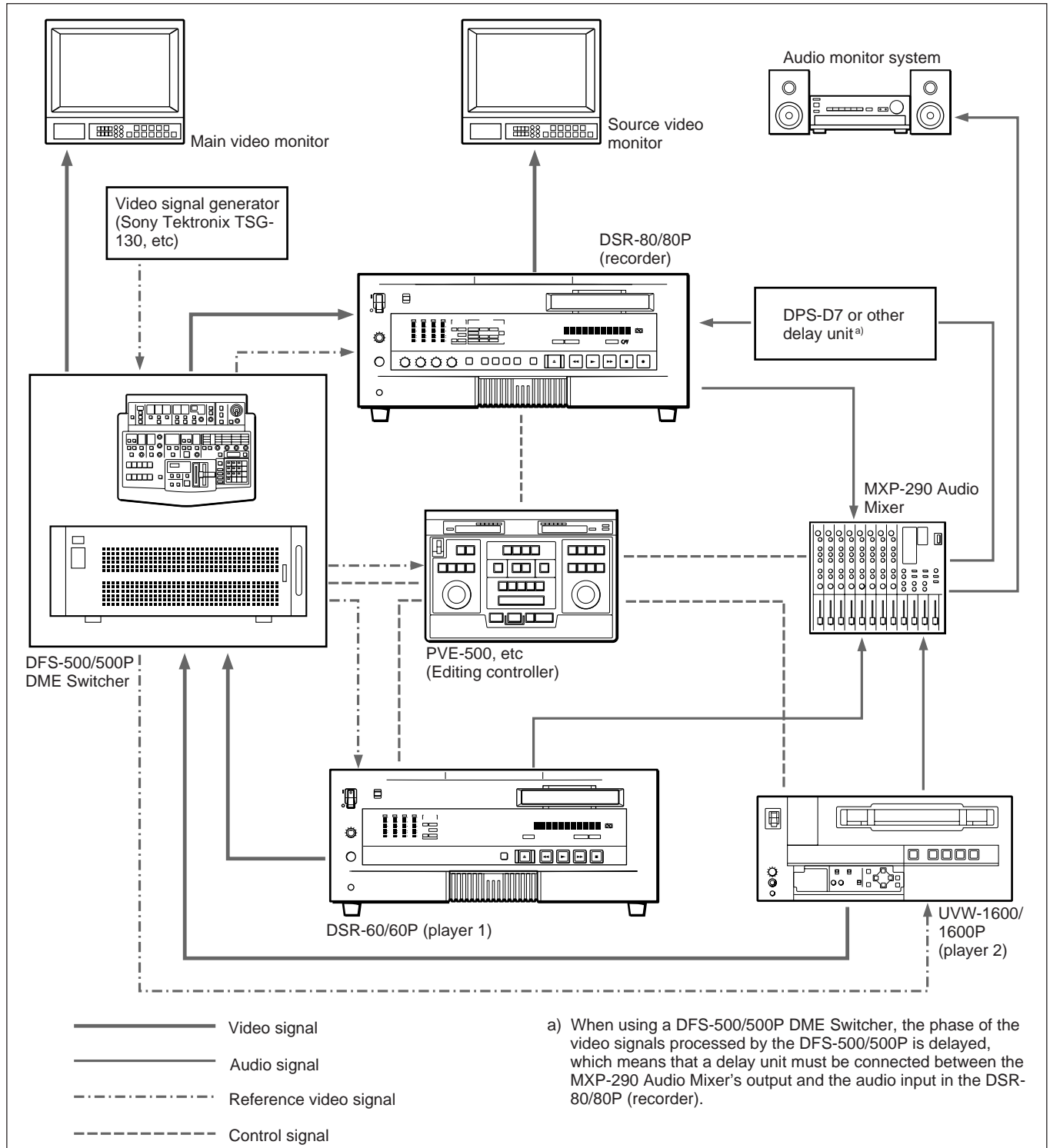

# Connections for an A/B Roll Editing System

## Audio monitor system connections

The following shows an example of audio monitor system connections.

For details of these connections, refer to each connected device's instruction manual.

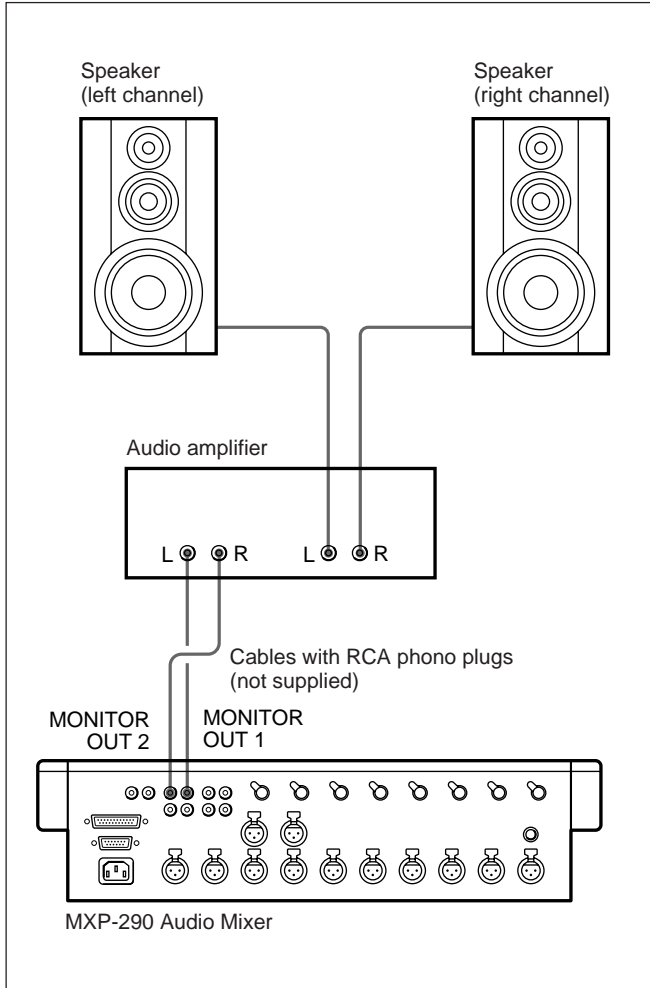

## Reference video signal connection

When you perform recording or editing, be sure to use a reference video signal.

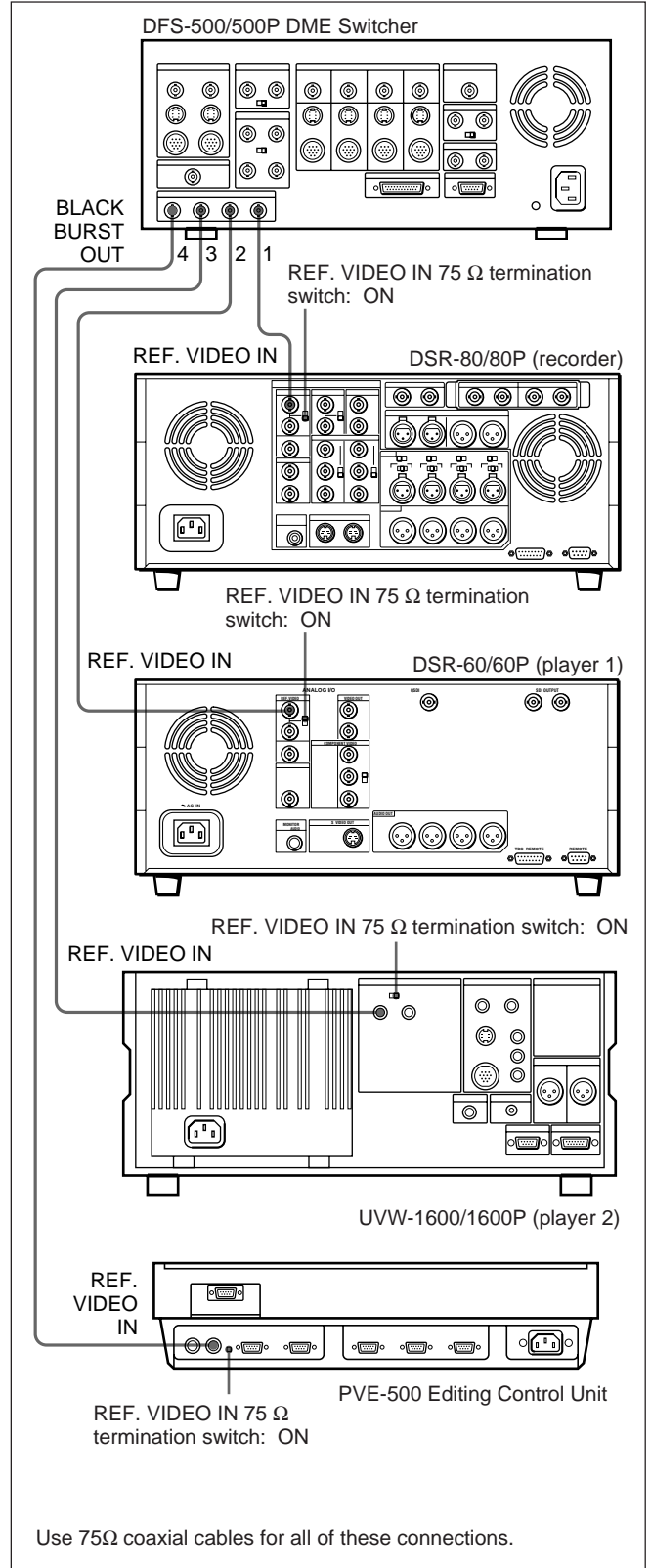

Use 75Ω coaxial cables for all of these connections.

## Control signal connections

The following shows an example of control signal connections to enable the editing controller to control all other A/B roll editing system devices.

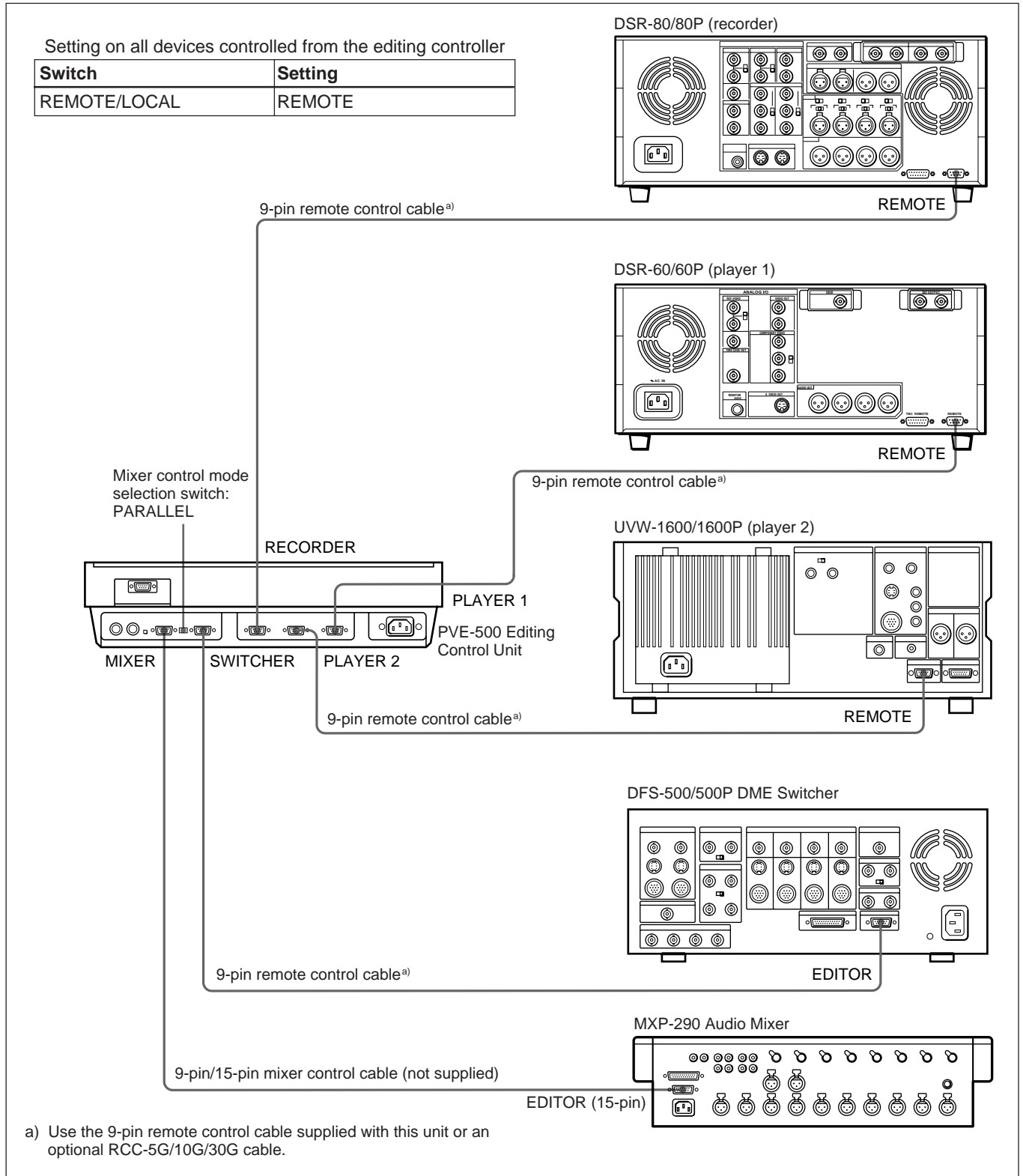

# Connections for an A/B Roll Editing System

## Video/audio signal connections

The following shows an example of video/audio signal connections in an A/B roll editing system. In this example, analog component signals are used as the video signals and XLR 3-pin connectors are used as audio input/output connectors.

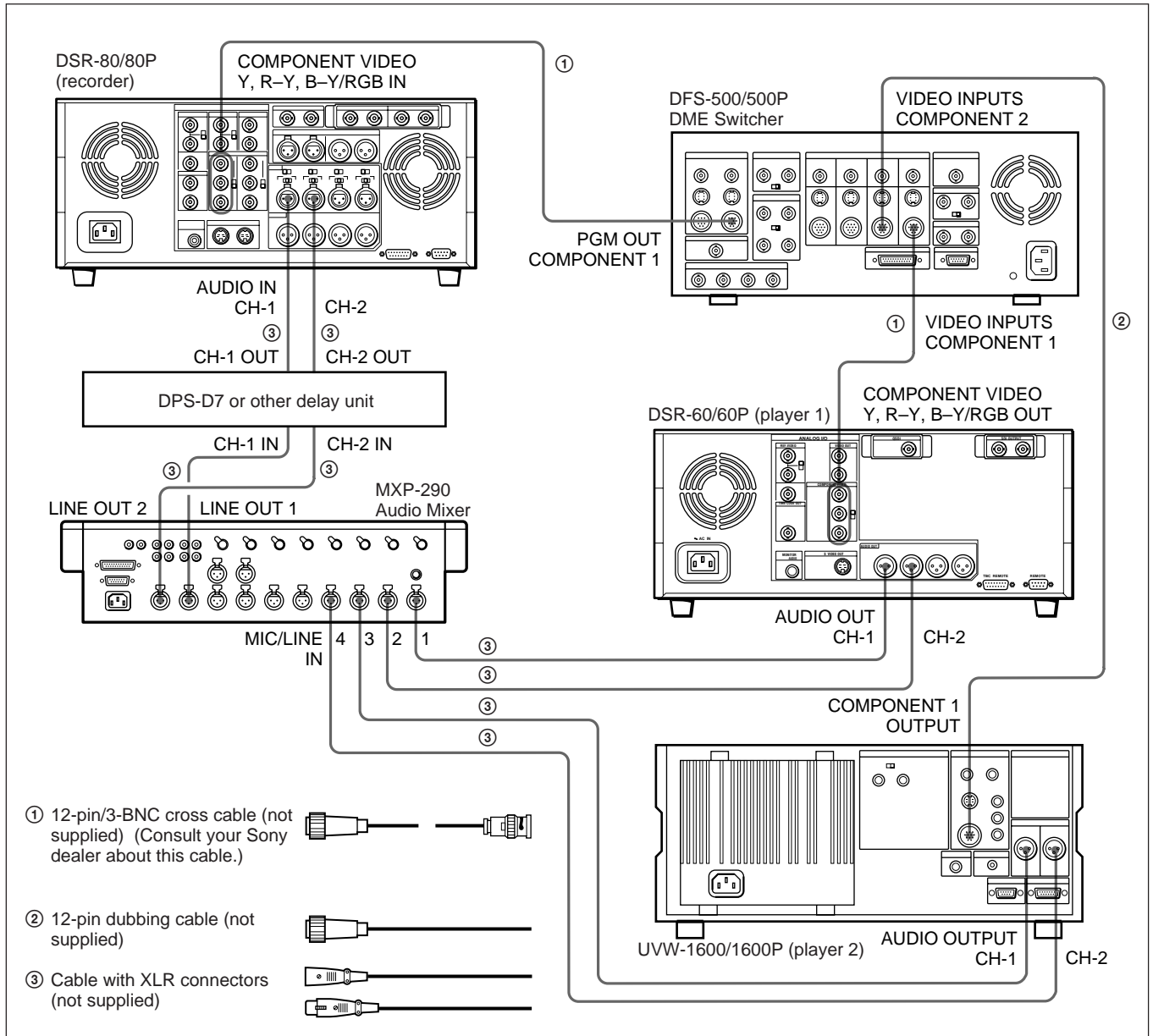

Settings on the DSR-80/80P (recorder)

Switch	Setting
AUDIO IN 600 Ω ON/OFF	ON
AUDIO IN -6dBm/0dBm/+4dBm	Normally +4dBm

For details of the video/audio input and audio mode settings, see “Settings for Recording” (page 19).

## Connection of a video monitor

Set up the following connections to enable monitoring of video and audio signals on a video monitor. In addition to video signals, you can have time data, the DSR-80/80P's operation mode, alarm messages, and other information displayed as text on the monitor screen by setting "CHARA. DISPLAY" under the DISPLAY CONTROL menu item to "ON" (this is the factory default setting).

For details of menu operations, see Chapter 4.

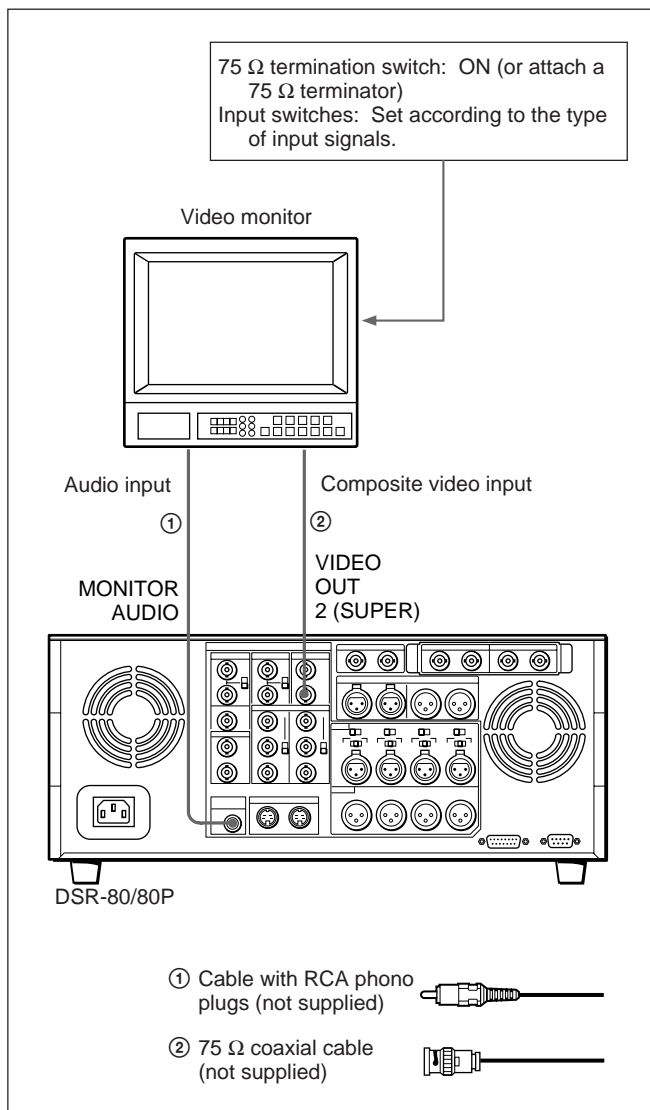

## Settings on an editing control unit

When connecting an editing control unit, make the settings as follows, according to the model.

### PVE-500

No settings are required.

### BVE-600/900/910/2000 (NTSC model) or FXE-100/120

Set the VCR constants as follows.

1	2	3	4	5	6	7	8	9	10	11	12	13	14	15
80	11	00	96	05	05	03	80	0A	08	FE	00	80	5A	FF

### BVE-600/900/910/2000 (PAL model) or FXE-100P/120P

Set the VCR constants as follows.

1	2	3	4	5	6	7	8	9	10	11	12	13	14	15
81	11	00	7D	05	05	02	80	0A	07	FE	00	80	4C	FF

### RM-450/RM-450CE

Set the DIP switches as follows.

#### • Left switches

7	6	5	4	3	2	1	0
OFF	–	–	OFF	–	–	–	–

#### • Right switches (RM-450)

7	6	5	4	3	2	1	0
OFF	–	OFF	ON	OFF	OFF	ON	ON

#### • Right switches (RM-450CE)

7	6	5	4	3	2	1	0
ON	–	OFF	ON	OFF	OFF	ON	ON

### BVE-800

Set the DIP switches as follows.

#### • SW2

1	2	3	4	5	6	7	8
ON	OFF	ON	ON	–	ON	ON	–

#### • SW3 (NTSC model)

1	2	3	4	5	6	7	8
OFF	ON	OFF	ON	–	ON	OFF	OFF

#### • SW3 (PAL model)

1	2	3	4	5	6	7	8
ON	ON	OFF	ON	–	ON	OFF	OFF

# Connections for QSDI Dubbing

The following shows an example of connections for QSDI dubbing (see page 38), with the DSR-80/80P used as the recorder and a DSR-60/60P as the player.

(Using a DSR-60/60P for QSDI dubbing requires an optional DSBK-110/110P QSDI Output Board.)

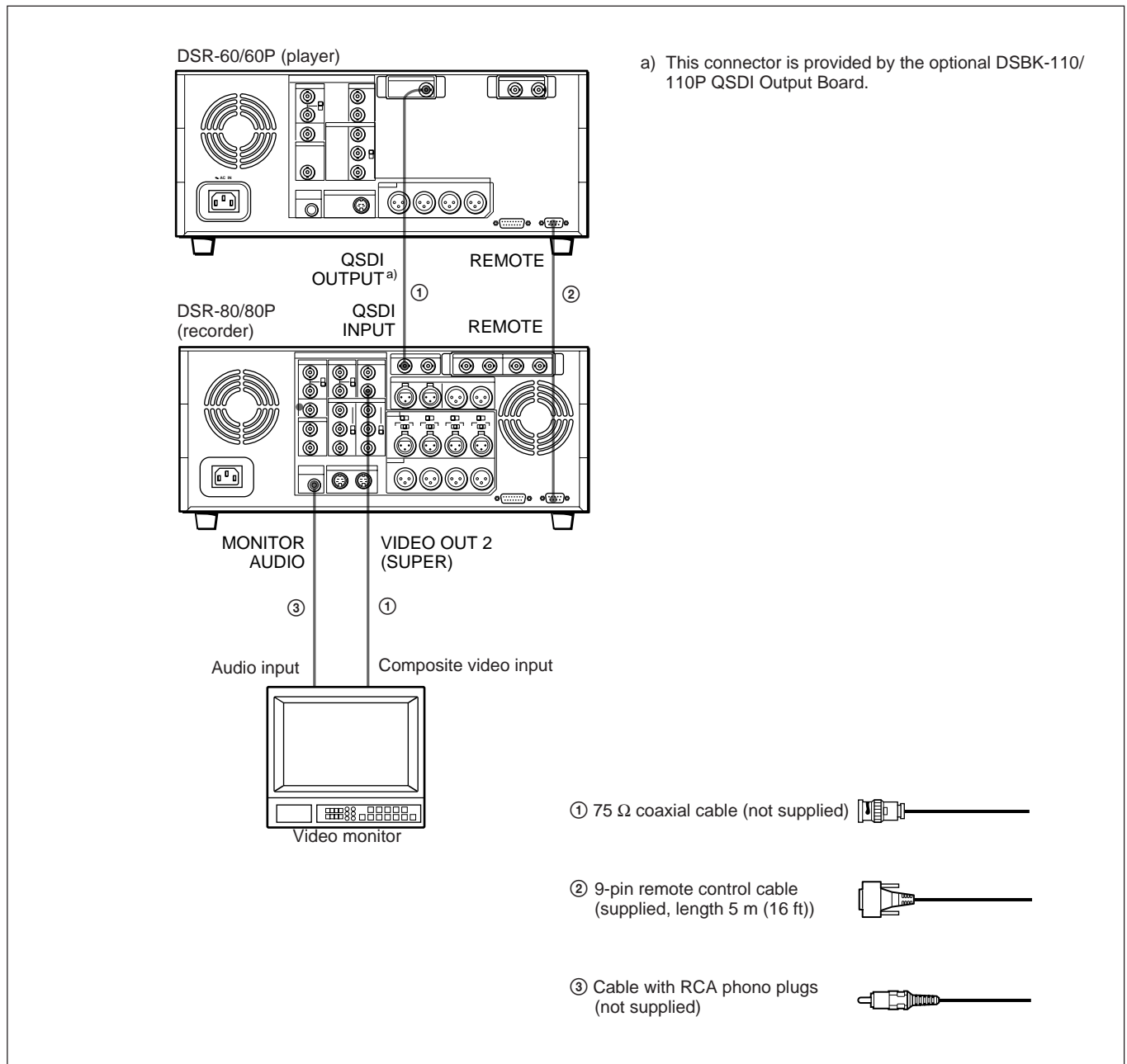

## DSR-80/80P (recorder) and DSR-60/60P (player) settings

Switch	Recorder	Player
REMOTE/LOCAL	LOCAL	REMOTE

# Connections for Analog Recording

The following shows connections for a system in which analog playback signals from another recorder or player are recorded on a DSR-80/80P. In this system, the video signals are analog component signals and the audio signals are recorded from audio channels 1 and 2.

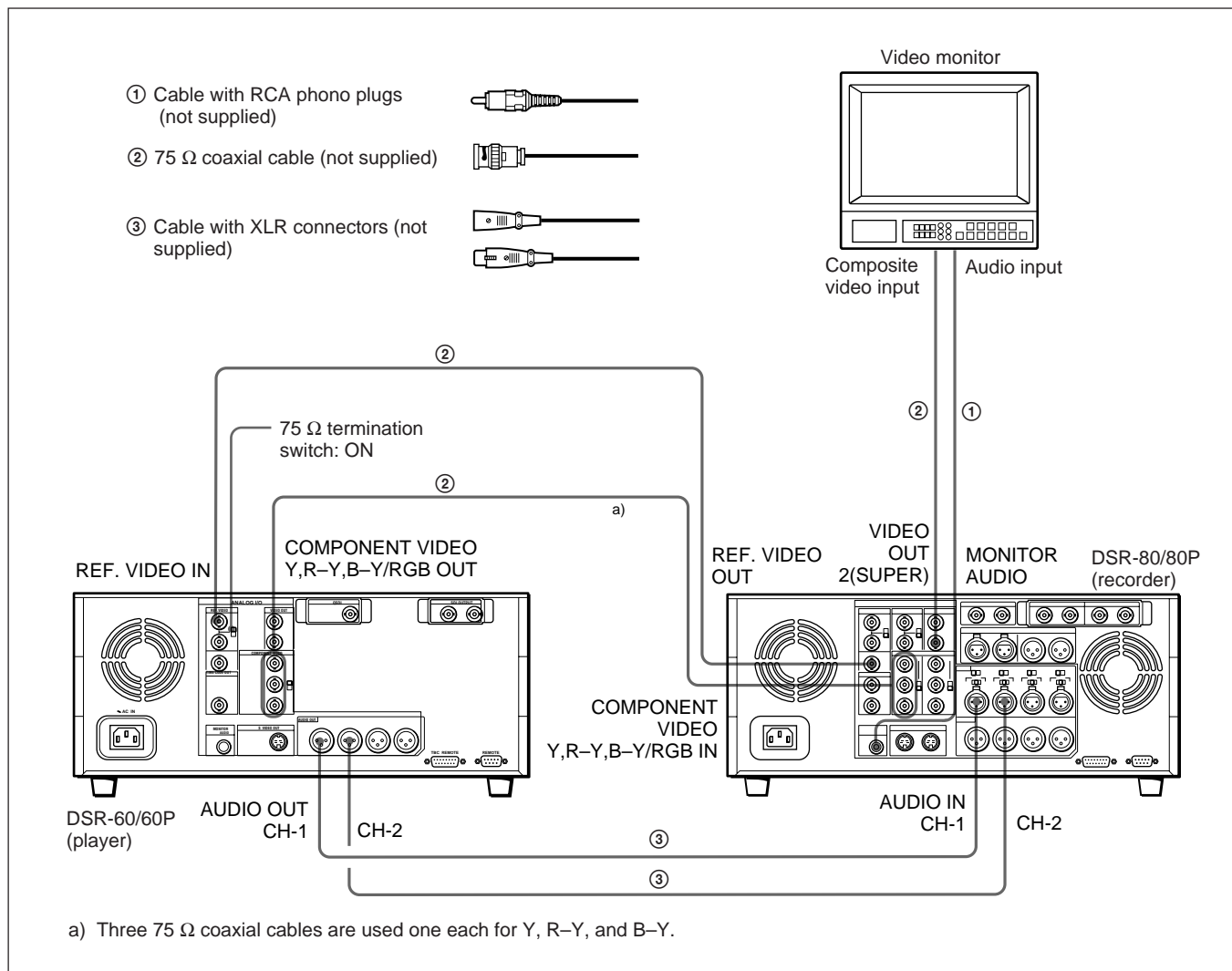

Settings on the DSR-80/80P

Switch/input/audio mode	Setting
REMOTE/LOCAL	REMOTE (when controlling the unit from an editing controller)
AUDIO IN 600 $\Omega$ ON/OFF	ON
AUDIO IN -6 dBm/0 dBm/+4 dBm	Normally +4 dBm
Video input	Component
Audio input	Analog
Audio mode	2-channel (48 kHz)

For details of the video/audio input and audio mode settings, see "Settings for Recording" (page 19).

# Adjusting the Sync and Subcarrier Phases

When using two or more players, as in an A/B roll editing system, phase synchronization of the signals (i.e. system sync) is necessary and for composite signals only, the subcarrier phase must also be in sync. If not, picture instabilities or color break-up may occur at edit points.

After configuring the editing system, use a vectorscope to adjust the sync and subcarrier phase of the recorder and players. Subcarrier phase adjustment is necessary when using composite signals and Y/C signals.

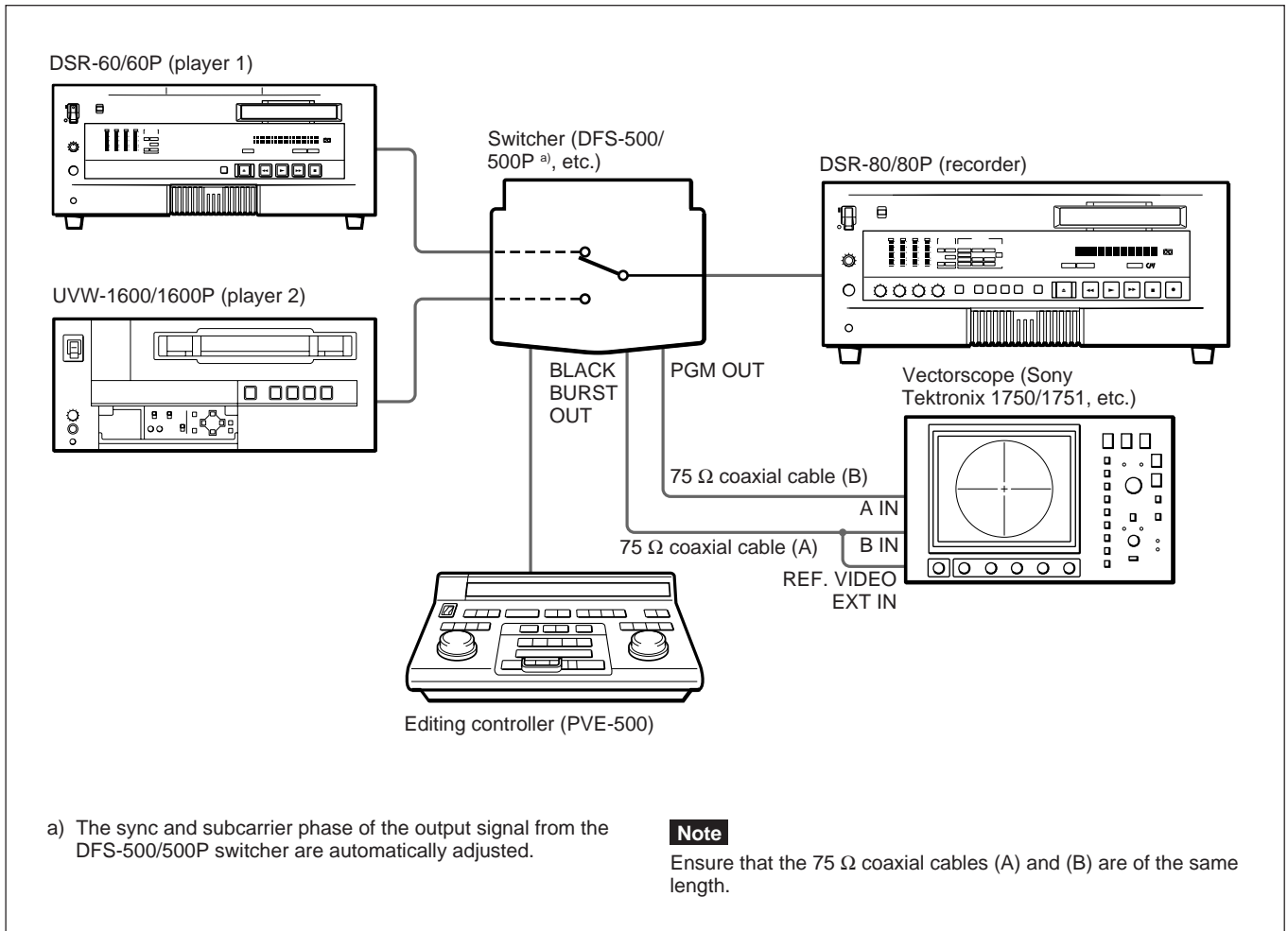

## Performing a phase adjustment operation

**1** Press the SCH button on the vectorscope.

The vectorscope switches to “SCH” mode.

**2** Press the B channel button on the vectorscope.

This displays the black burst signal from the switcher.

**3** Press the EXT button on the vectorscope.

This switches the vectorscope to external synchronization mode.

**4** Adjust the phase synchronization control on the vectorscope so that the sync and subcarrier phases are close to the reference line.

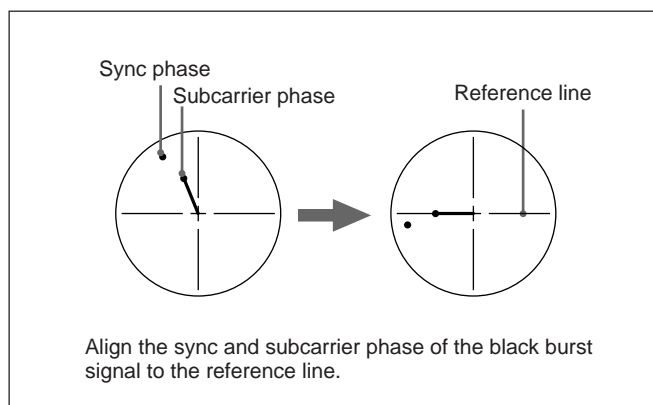

**5** Output the player 1 signal from the PVE-500.

**6** Press the A channel button on the vectorscope.

This displays the sync phase and subcarrier phase (composite signals only) of the signal from player 1.

**7** On player 1, adjust the SYNC and SC controls, using a Phillips screwdriver, so that the output from player 1 on channel (A) is in correct phase alignment with the black burst signal on channel (B).

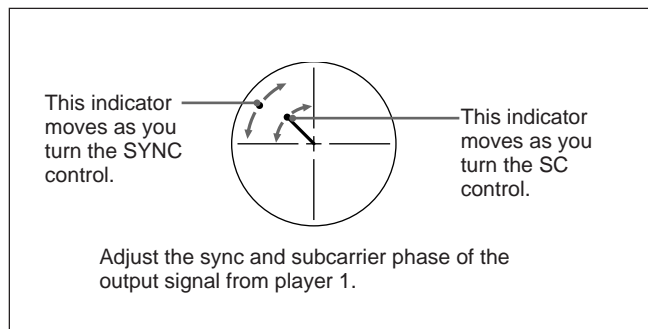

**Note**

When component signals are used the subcarrier phase indicator does not appear.

**8** Output the player 2 signal from the PVE-500, and repeat Steps 6 and 7 to adjust the sync and subcarrier phase of the output from player 2.



# Maintenance

## Condensation

If you move the unit suddenly from a cold to a warm location, or if you use it in a very humid place, moisture from the air may condense on the head drum. This is called condensation, and if a tape is run in this state, the tape may stick to the drum and can be easily damaged. To lessen the risk of this occurring, this unit is equipped with a condensation detection system.

### If condensation occurs while the unit is operating:

The alarm message “MOISTURE HAS BEEN DETECTED.” appears on the monitor screen, and the alarm message “HUMID!” on the time counter display. At the same time the unit ejects the cassette automatically. If this happens, leave the unit’s power on and wait until the alarm messages disappear.

### If the condensation alarm message appears immediately after powering on:

Leave the unit powered on and wait until the alarm message disappears. You cannot load a cassette into the unit while the alarm message is being displayed. Once the alarm message disappears, the unit is ready for use.

## Regular Checks

### Digital hours meter

The digital hours meter keeps cumulative counts of the total operating time, the head drum rotation time, the tape transport operating time, and the number of threading/unthreading operations. These counts can be displayed on the monitor screen and the time counter display of this unit. Use them as guidelines for scheduling maintenance.

In general, consult your Sony dealer about necessary periodic maintenance checks.

### Digital hours meter display modes

The digital hours meter has the following four display modes.

- **T1 (OPERATION) mode**  
The cumulative total hours during which the unit is powered on is displayed in 10-hour increments.
- **T2 (DRUM ROTATION) mode**  
The cumulative total hours of drum rotation with tape threaded is displayed in 10-hour increments.
- **T3 (TAPE RUNNING) mode**  
The cumulative total hours of tape transport operation is displayed in 10-hour increments.
- **CT (THREADING) mode**  
The cumulative number of tape threading/unthreading operation pairs is displayed in 10-operation pair increments.

For all modes except T1 (OPERATION), there are two types of count: a “trip” count, which is resettable, and the cumulative total from manufacture, which is unresettable.

### Displaying the digital hours meter

- 1 Press the MENU button on the menu control panel.

The menu selection level display appears on the monitor screen and the time counter display.

Menu selection level display

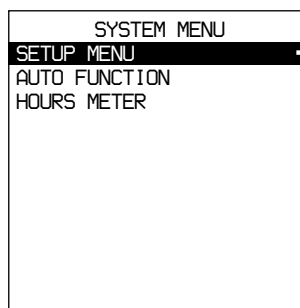

Monitor screen

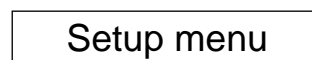

Time counter display

(Continued)

**2** Press the  $\downarrow$  button to select “HOURS METER”.

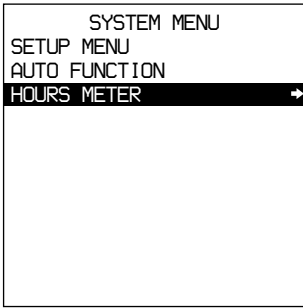

Monitor screen

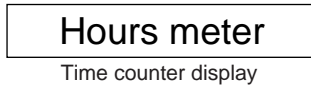

**3** Press the  $\Rightarrow$  button.

The cumulative counts by the digital hours meter are indicated on the monitor screen and the time counter display.

### Digital hours meter indications on the monitor screen

All four counts (T1, T2, T3, and CT) are indicated on the monitor screen.

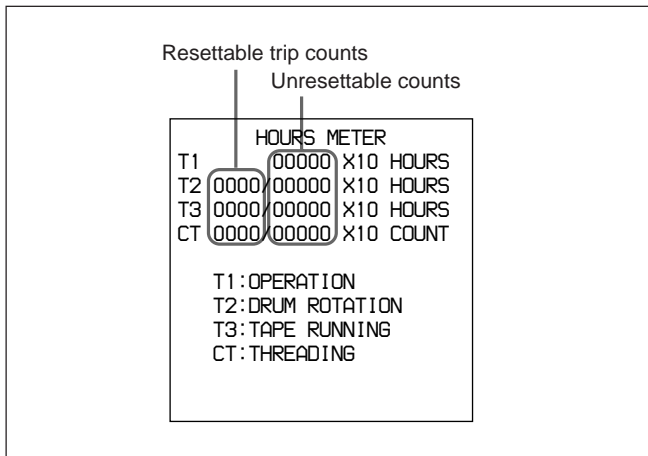

The four-digit value to the left of the slash is the resettable trip count, and the right value is the cumulative total from manufacture.

### Digital hours meter indications on the time counter display

One of the four indications appears on the time counter display at a time. Use the  $\uparrow$  and  $\downarrow$  buttons to change the item displayed.

Initially, only the trip value appears. Hold down the  $\Rightarrow$  button to display also the cumulative total from manufacture, which will appear to the right of the trip value and the slash.

The following illustrates the digital hours meter indications on the time counter display in all four display modes. The right-hand indication for each display mode is the indication you can view while holding down the  $\Rightarrow$  button on the menu control panel.

T1 (OPERATION) mode:



T2 (DRUM ROTATION) mode:



T3 (TAPE RUNNING) mode:



CT (THREADING) mode:



### To end the digital hours meter display

Press the MENU button on the menu control panel.

### Resetting the trip values

About this operation, consult your Sony dealer.

## Head Cleaning

Always use the PDVM-12CL Cleaning Cassette to clean the video and audio heads. You can run the cleaning cassette for 10 seconds per cleaning operation. Follow the instructions for the cleaning cassette, as inappropriate use of the cleaning cassette can damage the heads.

### To clean the heads

Insert the cleaning cassette. This automatically starts cleaning. You cannot operate any tape transport control buttons other than the EJECT button during the cleaning operation.

After about 10 seconds, the cleaning cassette will be automatically ejected.

# Troubleshooting

If an alarm message appears on the monitor screen or the time counter display, or if the unit appears to be malfunctioning, please check the following before contacting your Sony dealer.

Tape problems		
Symptom	Cause	Remedy
Recording is not possible.	The cassette's REC/SAVE switch is set to SAVE. <sup>a)</sup>	Set the REC/SAVE switch to REC.
The unit's tape transport control buttons (PLAY, F FWD, REW, etc.) do not work.	The REMOTE/LOCAL switch is set to REMOTE and "LOCAL ENABLE" under the OPERATIONAL FUNCTION menu item is set to "STOP & EJECT" or "ALL DISABLE". <sup>a)</sup>	Set the REMOTE/LOCAL switch to LOCAL and change the menu setting of "LOCAL ENABLE" to "ALL ENABLE". (See page 42.)
	No cassette is loaded. <sup>a)</sup>	Insert a cassette. (See page 24.)
The NOT EDITABLE indicator on the front panel lights up.	The audio recording mode selected on this unit does not coincide with that of the loaded tape. <sup>a)</sup>	<ul style="list-style-type: none"> <li>When your current purpose is editing, set the REMOTE/LOCAL switch to LOCAL and set the unit for the same audio recording mode as with the tape, then reset the REMOTE/LOCAL switch to REMOTE.</li> <li>When your current purpose is recording, you can use the tape currently loaded in the unit.</li> </ul>
	The recording format of the currently loaded tape is "DV". <sup>a)</sup>	<ul style="list-style-type: none"> <li>If you are using this unit as the recorder for editing, you cannot use the currently loaded tape as a record tape. Replace it with one recorded in the "DVCAM" format.</li> <li>If you are using the unit as the player for editing, you can use this tape as a source tape.</li> </ul>

Time data problems		
Symptom	Cause	Remedy
Cannot freely set the time data's initial value.	"TC MODE" under the TIME CODE menu item has been set to "EXT REGEN". <sup>a)</sup>	Change the menu setting of "TC MODE" to "INT PRESET". (See page 45.)
	CNT is selected as the time data type to be displayed. (The "COUNTER" time data type indicator is lit.) <sup>a)</sup>	Press the COUNTER SELECT button to make the "TC" or "U-BIT" time data type indicator light up.
	The REMOTE/LOCAL switch is set to REMOTE and "LOCAL ENABLE" under the OPERATIONAL FUNCTION menu item is set to "STOP & EJECT" or "ALL DISABLE". <sup>a)</sup>	Set the REMOTE/LOCAL switch to LOCAL and change the menu setting of "LOCAL ENABLE" to "ALL ENABLE". (See page 42.)
The tape is running, but the time data is not shown in the time counter display.	The MENU button or TC PRESET button on the menu control panel has been pressed.	Press the button once again to exit the menu control mode, time code preset mode, or digital hours meter display mode. (In either of these modes, the time data is not shown in the time counter display.)
	The "U-BIT" time data type indicator is lit.	Press the COUNTER SELECT button to make the "COUNTER" or "TC" time data type indicator light up.

Input problems		
Symptom	Cause	Remedy
It is not possible to record a QSDI signal.	No QSDI signal is input to the unit. <sup>a)</sup>	Connect a QSDI signal to the QSDI INPUT connector.

a) In these states, an alarm message appears on the monitor screen and on the time counter display.

# Troubleshooting

Monitor problems		
Symptom	Cause	Remedy
Data is not superimposed on the monitor screen.	“CHARA. DISPLAY” under the DISPLAY CONTROL menu item is set to “OFF”.	Set “CHARA. DISPLAY” to “ON”. (See page 43.)
	The monitor is not connected to the VIDEO OUT 2 (SUPER) connector of this unit.	Connect the monitor to the VIDEO OUT 2 (SUPER) connector. (You must make this connection to display any type of text on the monitor.)
The image on the monitor's screen is too bright.	The 75 Ω termination switch for video input on the monitor is in the OFF position or a 75 Ω terminator is not fitted to its video input connector.	Set the 75 Ω termination switch to ON or connect a terminator.
The image on the monitor's screen is too dark.	In a video signal loop-through connection of video monitors, 75 Ω termination switches for video input on monitors other than the loop-end monitor are in the ON position.	Set the 75 Ω termination switches to OFF on all monitors other than the loop-end monitor .
The image is too dark when recording a composite video signal.		

Audio problems		
Symptom	Cause	Remedy
When an AES/EBU, SDI or QSDI digital audio input is selected, the AUDIO INPUT LEVEL control knobs do not work.	“DIGITAL INPUT” under the AUDIO CONTROL menu item is set to “BYPASS”.	Set “DIGITAL INPUT” to “VARIABLE”. (See page 47.)  <b>Note</b> To be able to perform this operation, it is necessary to set the menu item “MENU GRADE” to “ENHANCED”. (See page 47.)
When a QSDI signal from a player VCR is selected as the input to this unit, putting the player into jog mode stops this unit from outputting an EE audio signal.	“QSDI AUDIO MON” under the OPERATIONAL FUNCTION menu item is set to “QSDI”.	Change the menu setting of “QSDI AUDIO MON” to a setting other than “QSDI”, and input an audio signal corresponding to the new setting. (See page 43.)  <b>Note</b> To be able to perform this operation, it is necessary to set the menu item “MENU GRADE” to “ENHANCED”. (See page 47.)

Editing problems		
Symptom	Cause	Remedy
Execution of video editing in insert mode causes subcode data recorded on tape other than time code data to disappear from tape.	This phenomenon cannot be avoided with an editing system using this unit as the recorder.	
During audio editing in insert mode, a strange image appears on the video monitor screen like a partial frozen image of a frame immediately before the IN point being mixed in the playback picture.	This phenomenon cannot be avoided with an editing system using this unit as the recorder, but editing itself will be achieved exactly as you have designed.	

## Error Messages

This unit is provided with a self-diagnostic function that detects internal abnormalities. When it detects an abnormality, it outputs an error message to the monitor screen and indicates an error code in the time counter display.

If an error message appears, follow the direction indicated under the message in the monitor screen.

### Note

To display error messages on the monitor screen, it is necessary for the monitor to be connected to the VIDEO OUT 2 (SUPER) connector, and for “CHARA. DISPLAY” under the DISPLAY CONTROL menu item to be set to “ON” (factory default setting).

For details of menu settings, see Chapter 4.

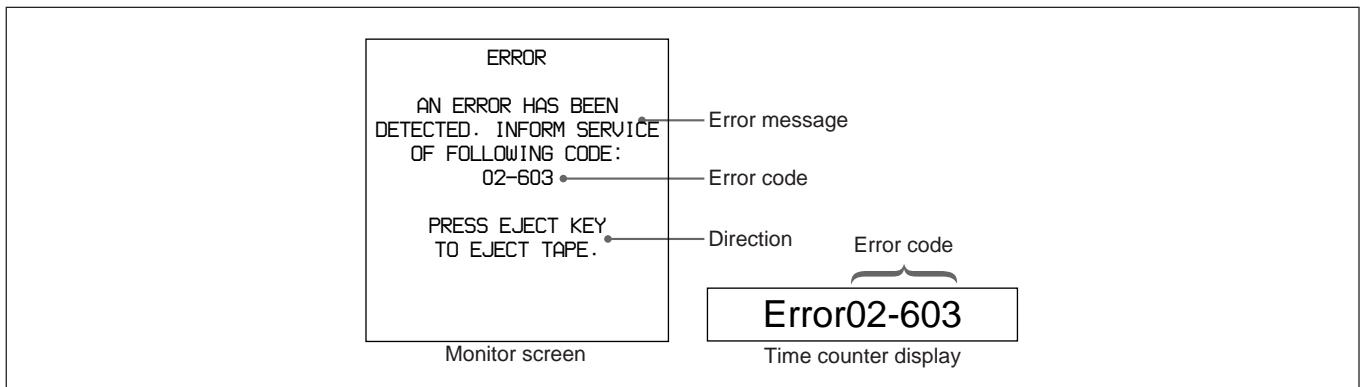

## Alarm Messages

When a setting, connection or operation error has been made, or when a problem such as condensation on heads has occurred, the unit outputs alarm messages

such as the ones shown below to the monitor screen and the time counter display.

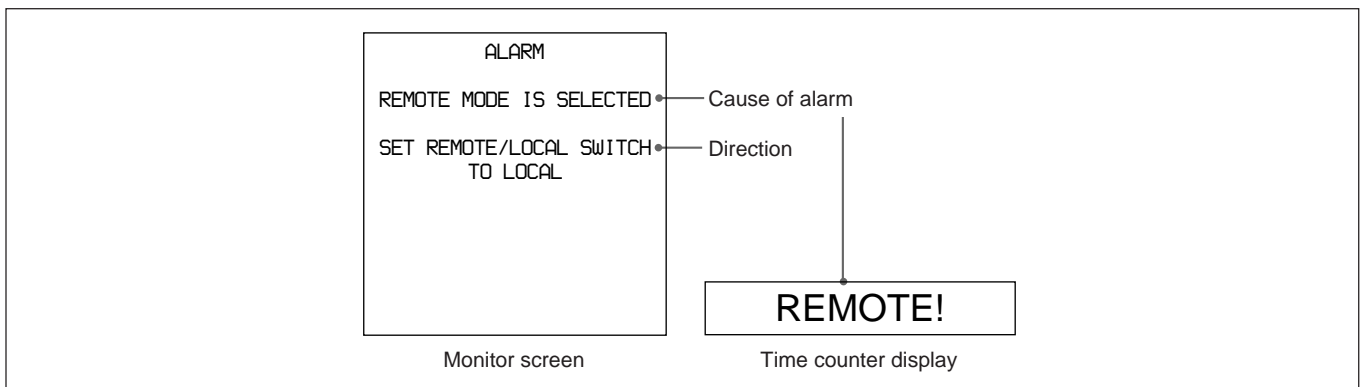

If an alarm message appears, follow the direction indicated under the message in the monitor screen.

### Note

To display alarm messages on the monitor screen, it is necessary for the monitor to be connected to the

VIDEO OUT 2 (SUPER) connector, and for “CHARA. DISPLAY” and “ALARM” under the DISPLAY CONTROL menu item to be set to “ON” (factory default setting) and “REF. ALARM” to be set to “ON” or “ON (LIMITED)” (factory default setting).

For details of menu settings, see Chapter 4.

# Troubleshooting

## List of alarm messages and associated directions

Here is a list of alarm messages and associated directions to appear on the monitor screen. It also shows the corresponding alarm messages to appear on the time counter display of this unit.

In this list the “Causes” of alarm are arranged in alphabetic order of the first word of their phrases.

Alarm messages and associated directions

Alarm message on monitor screen Cause	Direction	Alarm message on time counter display
A black/white signal is being used for REF. VIDEO.	Supply a color signal when using composite or S-video output signals.	B&W REF!
A cleaning tape has been inserted.	The tape will automatically be ejected after cleaning is completed.	Cleaning Tp
A non-standard ref. signal is being used for REF. VIDEO.	Use a standard signal.	REF NON-STD
Abnormal settings selected in setup menu.	Correct the setup menu settings. Contact your Sony dealer if this alarm message appears again after making corrections.	ILL. SETUP
Audio not editable on this tape.	Use a tape recorded in 2-channel (48 kHz) or 4-channel (32 kHz) mode.	2CH/32kHz!
		Fs 44.1kHz!
	Use a tape having audio signals recorded in locked mode.	UNLOCK mode
Audio REC mode selection different from audio on tape.	Select the same audio recording mode as that of the tape.	A mode err
Audio REC (recording) mode cannot be changed during recording.	—	REC mode!
Audio REC (recording) mode cannot be changed in PB (playback) mode.	Enter the unit into EE mode.	PB mode!
Counter mode is selected.	Use the COUNTER SELECT button to make the TC or U-BIT indicator light.	CNT mode!
Input selection cannot be changed in REC (recording) mode.	—	REC mode!
Input signal does not conform to DVCAM/DV format.	—	Unknown Sig
Input signal is 625/50.	—	625/50 sig!
Input signal is 525/60.	—	525/60 sig!
Input signal is not ×1 mode.	Use normal-speed playback mode.	not ×1 sig!
Input video is not detected.	Check the INPUT MODE VIDEO indicators for current video selection, and supply an appropriate video signal.	No INPUT!

Alarm messages and associated directions (Continued)

Alarm message on monitor screen Cause	Direction	Alarm message on time counter display
Key is jammed.	Check the following buttons: EJECT, STOP, F FWD, REW, PLAY, REC, $\uparrow$ , $\downarrow$ , $\leftarrow$ , $\rightarrow$ , SET (YES), TC PRESET, MENU, RESET (NO), INPUT SELECT (VIDEO, AUDIO CH-1 CH-1/2, AUDIO CH-2 CH-3/4, QSDI), COUNTER SELECT, AUDIO REC SELECT	Key jammed!
Moisture has been detected.	Keep the power on and wait until this alarm message disappears.	HUMID!
No cassette in VTR.	Load a cassette.	No Cass.!
Record inhibit plug on the cassette is set to inhibit.	Set the REC/SAVE switch on the cassette to REC.	REC INHI.!
Remote mode is selected.	Set the REMOTE/LOCAL switch to LOCAL.	REMOTE!
Tape cannot be replayed.	Use a tape having signals recorded in 525/60 format.	625/50 Tape
	Use a tape having signals recorded in 625/50 format.	525/60 Tape
Tape end has been detected.	Use a new cleaning tape.	Tape end!
Tape not editable.	Use a tape recorded in DVCAM format.	Not DVCAM!
	Use a tape having signals recorded in 525/60 format.	625/50 Tape
	Use a tape having signals recorded in 625/50 format.	525/60 Tape
Tape not usable.	Use DVCAM/DV ME (metal-evaporated) tape.	MP Tape!
		ILL. Tape!
TC EXTERNAL is selected.	Use the setup menu to set "TC MODE" to "INT PRESET".	TC EXT!
TCG REGEN mode is selected.	Use the setup menu to set "TC MODE" to "INT PRESET".	REGEN mode!
TCG RUN mode is set to REC RUN.	Use the setup menu to set "RUN MODE" to "FREE RUN".	REC RUN!



## Operation and storage locations

Avoid operation or storage in any of the following places.

- Location subject to extremes of temperature (operating temperature range 5°C to 40°C (41°F to 104°F))
- Location subject to direct sunlight for long periods, or close to heating appliances (Note that the interior of a car left in summer with the windows closed can exceed 50°C (122°F).)
- Damp or dusty places
- Location subject to severe vibrations
- Location near equipment generating strong electromagnetic emissions
- Location near transmitting stations generating strong radio waves

## Operate the unit in a horizontal position

This unit is designed to be operated in a horizontal position. Do not operate it on its side, or tilted through an excessive angle (exceeding 20°).

## Avoid violent impacts

Dropping the unit, or otherwise imparting a violent shock to it, is likely to cause it to malfunction.

## Do not obstruct ventilation openings

To prevent the unit from overheating, do not obstruct ventilation openings, by for example wrapping the unit in a cloth while it is in operation.

## Care

If the casing or panel is dirty, wipe it gently with a soft dry cloth. In the event of extreme dirt, use a cloth steeped in a natural detergent to remove the dirt, then wipe with a dry cloth. Applying alcohol, thinners, insecticides, or other volatile solvents may result in deforming the casing or damaging the finish.

## Shipping

Pack the unit in its original carton or equivalent packing, and take care not to impart violent shocks in transit.

# Specifications

## General

### Signal system

DSR-80: NTSC

DSR-80P: PAL

### Power requirements

DSR-80: 120 V AC, 50/60 Hz

DSR-80P for Europe:  
220 to 240 V AC, 50/60 Hz

DSR-80P for USA and Canada:  
120 V AC, 50/60 Hz

### Power consumption (with all options installed)

DSR-80: 140 W/120 V

DSR-80P for Europe:  
145 W/220 V

DSR-80P for USA and Canada:  
140 W/120 V

### Operating temperature

5°C to 40°C (41°F to 104°F)

### Storage temperature

-20°C to +60°C (-4°F to +140°F)

### Operating relative humidity

Less than 80%

### Storage relative humidity

Less than 90%

### Mass

19 kg (41 lb 14 oz)

### Dimensions (w/h/d, excluding projections)

427 × 174 × 494 mm  
(16 7/8 × 6 7/8 × 19 1/2 inches)

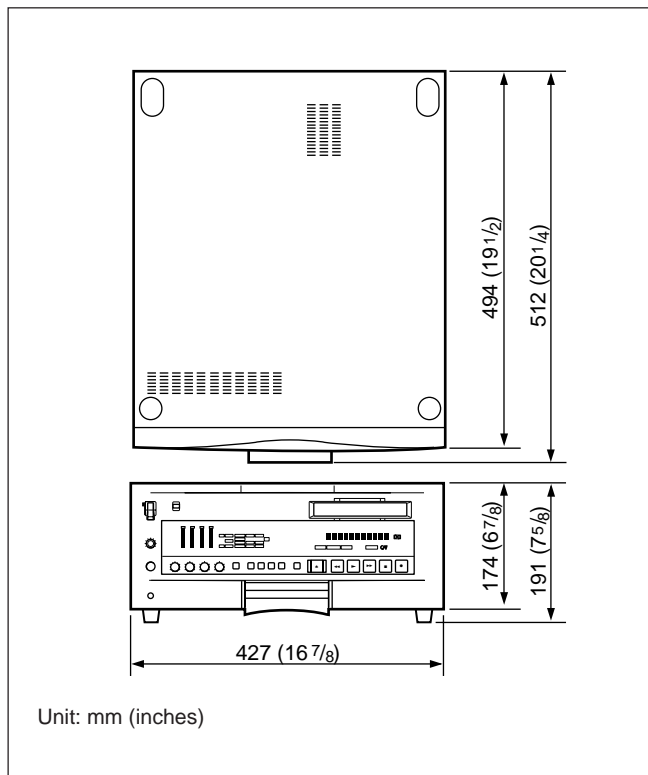

## Tape transport control system

### Tape speed

DSR-80: 28.193 mm/s

DSR-80P: 28.221 mm/s

### Recording/playback time

Using PDV-184ME standard-size cassette:  
Maximum 184 minutes

Using PDVM-40ME mini-size cassette:  
Maximum 40 minutes

### Fast forward/rewind time

Using PDV-184ME standard-size cassette:  
Less than 3 minutes

Using PDVM-40ME mini-size cassette:  
Less than 1 minute

### Search speed

When controlling via RS-422A interface:

Maximum 32 times normal in both directions (with color picture)

Maximum 85 times normal in both directions (without color picture)

When controlling from optional DSRM-10:

Jog mode: 0 (still) to 2 times normal in both directions

Shuttle mode: 8 speeds from 0 (still) to 16 times normal in both directions

Digital slow mode: 3 speeds, (0 (still), 1/5, 1/10 normal) in both directions

Jog audio mode: 1 to 1/30 normal in both directions

## Video performance

### Bandwidth (when using analog component interface)

DSR-80: Y: 5.0 MHz +1.0 dB/-1.0 dB  
R-Y, B-Y: 1.5 MHz +1.0 dB/  
-5.0 dB

DSR-80P: Y: 5.5 MHz +1.0 dB/-2.0 dB  
R-Y, B-Y: 2.0 MHz +1.0 dB/  
-2.0 dB

### S/N (when using analog component interface)

More than 55 dB

### K-factor (K2T, KPb)

Less than 2.0%

### Y/C delay

Less than 30 ns

---

## Audio performance

Frequency response	2-channel (48 kHz) mode: 20 Hz to 20 kHz +0.5 dB/−1.0 dB 4-channel (32 kHz) mode: 20 Hz to 14.5 kHz +0.5 dB/−1.0 dB
Dynamic range	More than 85 dB
Distortion (THD + N)	Less than 0.05% (48 kHz)

---

## Input connectors

### Digital signal inputs

QSDI INPUT	BNC type, QSDI format (270 Mbps)
SDI INPUT (with optional DSBK-120/120P SDI Input/Output Board installed)	BNC type (×2, active-through), Serial Digital Interface format (270 Mbps), SMPTE 259M/CCIR656-III

### Analog video inputs

REF. VIDEO IN	BNC type (×2, loop-through) Black burst 0.286 V (DSR-80) or 0.3 V (DSR-80P), 75 Ω, negative sync Composite sync 2.0 V, 75 Ω, negative sync (for RGB four-wire signal input)
VIDEO IN	BNC type (×2, loop-through), composite, 1.0 Vp-p, 75 Ω, sync negative
COMPONENT VIDEO IN	BNC type ×3 for YRB input Y: 1.0 Vp-p, 75 Ω, negative sync R–Y/B–Y: 0.7 Vp-p (75% color bars for DSR-80 or 100% color bars for DSR-80P), 75 Ω for RGB input (100% color bars) G: 1.0 Vp-p, 75 Ω, negative sync (for three-wire operation) 0.7 Vp-p, 75 Ω (for four-wire operation) B: 0.7 Vp-p, 75 Ω R: 0.7 Vp-p, 75 Ω
S VIDEO IN	DIN 4-pin Y: 1.0 Vp-p, 75 Ω C: 0.286 Vp-p (DSR-80) or 0.3 Vp-p (DSR-80P), 75 Ω (burst level)

### Analog audio inputs

AUDIO IN	XLR 3-pin, female (×4), +4/0/−6 dBu, 600 Ω (with 600 Ω ON/OFF switch set to ON), 10 kΩ (with switch OFF), balanced
----------	--

### Digital audio inputs

DIGITAL AUDIO (AES/EBU) INPUT	XLR 3-pin, female (×2), 110 Ω, balanced
-------------------------------	---

### Time code input

TIME CODE IN (with optional DSBK-130/130P Time Code Input/Output Board installed)	BNC type, SMPTE time code (DSR-80) or EBU time code (DSR-80P), 0.5 Vp-p to 18 Vp-p, 3.3 kΩ, unbalanced
---	--

---

## Output connectors

### Digital signal outputs

QSDI OUTPUT	BNC type, QSDI format (270 Mbps)
SDI OUTPUT (with optional DSBK-120/120P SDI Input/Output Board installed)	BNC type (×2, active-through), Serial Digital Interface format (270 Mbps), SMPTE 259M/CCIR656-III

### Analog video outputs

REF. VIDEO OUT	BNC type ×1 Black burst 0.286 V (DSR-80) or 0.3 V (DSR-80P), 75 Ω, negative sync Composite sync 2.0 V, 75 Ω, negative sync (for RGB four-wire signal output)
VIDEO OUT 1, 2 (SUPER)	BNC type (×2), composite, 1.0 Vp-p, 75 Ω, sync negative
COMPONENT VIDEO OUT	BNC type ×3 (Y/R–Y/B–Y ↔ RGB switchable) for YRB output Y: 1.0 Vp-p, 75 Ω, negative sync R–Y/B–Y: 0.7 Vp-p (75% color bars for DSR-80 or 100% color bars for DSR-80P), 75 Ω

# Specifications

for RGB output (100% color bars)  
G: 1.0 Vp-p, 75 Ω, negative sync  
(for three-wire operation) or  
0.7 Vp-p, 75 Ω (for four-wire  
operation)

B: 0.7 Vp-p, 75 Ω

R: 0.7 Vp-p, 75 Ω

S VIDEO OUT DIN 4-pin, Y and C separated  
Y: 1.0 Vp-p, 75 Ω  
C: 0.286 Vp-p (DSR-80) or  
0.3 Vp-p (DSR-80P), 75 Ω  
(burst level)

## Analog audio outputs

AUDIO OUT XLR 3-pin, male (×4), +4 dBu,  
600 Ω loading, low impedance,  
balanced

MONITOR AUDIO  
Phono jack, -6 dBu +1 dBu/-1 dBu  
47 kΩ, unbalanced

## Digital audio outputs

DIGITAL AUDIO (AES/EBU) OUTPUT  
XLR 3-pin, male (×2), 110 Ω,  
balanced

## Output for headphones

HEADPHONES Stereo phone jack, -16 dBu  
+2 dBu/-2 dBu, 8 Ω, unbalanced

## Time code output

TIME CODE OUT (with optional DSBK-130/130P  
Time Code Input/Output Board installed)  
BNC type, SMPTE time code  
(DSR-80), EBU time code (DSR-  
80P), 2.2 Vp-p +3 dBu/-3 dBu,  
600 Ω, unbalanced

## Remote control connectors

REMOTE D-sub 9-pin, for connection of  
editing controller<sup>1)</sup>, RS-422A  
standard

CONTROL S Stereo minijack, for connection of  
SIRCS-system remote control  
unit (SVRM-100/100A and  
DSRM-10)

TBC REMOTE D-sub 15-pin, for connection of  
TBC remote controller<sup>2)</sup>

## Accessories supplied

AC power cord (1)  
RCC-5G 9-pin remote control cable (1)  
Operating Instructions (1)  
ClipLink™ Guide (1)

## Optional accessories

DSBK-120/120P SDI Input/Output Board  
DSBK-130/130P Time Code Input/Output Board  
RCC-5G/10G/30G 9-pin remote control cable (length  
5 m (16 ft)/10 m (33 ft)/30 m (98 ft))  
RMM-130 Rack Mount Kit  
Digital video cassette  
Standard size: PDV-64ME/94ME/124ME/184ME  
Mini size: PDVM-12ME/22ME/32ME/40ME  
PDVM-12CL Cleaning Cassette

## Related equipment

ES-7 EditStation  
Linear editing controller (PVE-500, RM-450/450CE,  
BVE-600/800/910/2000/9100/9100P, etc.)  
DFS-500/500P DME Switcher  
DXC-D30/D30P Color Video Camera  
DSR-1/1P Digital Videocassette Recorder  
DSR-85/85P Digital Videocassette Recorder  
DSR-60/60P Digital Videocassette Player  
DSR-130/130P Digital Camcorder  
SVRM-100/100A Remote Control Unit  
DSRM-10 Remote Control Unit  
TBC remote controller (UVR-60/60P, BVR-50/50P)

Design and specifications are subject to change  
without notice.

1) ES-7, PVE-500, RM-450/450CE, BVE-600/800/910/  
2000/9100/9100P, etc.

2) UVR-60/60P, etc.

**A/B roll editing**

An editing method that uses two or more playback VCRs to create special effects such as dissolve and wipe, and uses one record VCR to record the results of the editing. Using an editing controller allows efficient control of the VCRs and very precise editing.

**B–Y signal**

A chrominance signal determined by subtracting the Y (luminance) signal from the B (blue) signal. One of the component signals.

**Capstan**

A drive mechanism that moves the tape at a specified speed. Its rotation normally synchronizes with a reference sync signal.

**Chrominance signal**

Color signal containing color information such as hue and saturation. Also called C signal.

**Component video signals (RGB)**

Video signals comprising separate component signals for the primary colors red, green, and blue. Widely used for display connections in computer systems. There are two ways of connecting the reference signal: three-wire and four-wire.

**Component signal (YRB)**

A video signal consisting of a luminance signal (Y) and two chrominance signals (R–Y, B–Y).

**Composite signal**

A composite video signal containing video, burst and sync signals.

**Condensation**

Condensation of moisture on the tape transport mechanisms of VCRs including the head drum. If moisture condenses on the head drum, the tape adheres to the drum and causes malfunction.

**EBU**

European Broadcasting Union. Established by broadcasting and related organizations in Europe.

**EE mode**

EE is an abbreviation of “Electric to Electric”. Video and audio signals are supplied to the VCR’s internal circuits, but not to the recording heads.

**Linear editing**

Editing while playing back video and audio signals recorded on video tape. *See also* “Non-linear editing”.

**Loading**

When being loaded, the tape is pulled out of the cassette case and threaded along the specified tape path and wrapped round the drum to be ready for recording or playback. Generally, this is done automatically when you place the cassette at the cassette entrance of the VCR. Also called threading.

**Loop-through connection**

A connection which allows a signal input to an input connector to pass through the unit and exit from an output connector as input to external equipment. Also called bridging connection.

**Luminance signal**

The signal that determines the brightness of the picture. Also called Y signal. One of the component signals.

**Non-linear editing**

Editing while playing back video and audio signals recorded on hard disks. Video scenes stored on disk can be cued up quickly, for increased editing efficiency. *See also* “Linear editing”.

**R–Y signal**

A chrominance signal determined by subtracting the Y (luminance) signal from the R (red) signal. One of the component signals.

**Reference video signal**

A video signal consisting of a sync signal or sync and burst signals, used as a reference.

**S/N**

Abbreviation of Signal-to-Noise (ratio). The higher the S/N value, the less noise and higher the picture quality.

**Search mode**

A VCR operating mode used when searching for specific scenes, by viewing the video output or time code values while playing back the tape at various speeds in forward or reverse direction.

**Servo lock**

Synchronizing the drum rotation phase and tape transport phase with a reference signal during playback and recording so that the video heads scan the tape in the same pattern during playback and recording.

**Standby Off mode**

One of two conditions in the stop mode. The drum does not rotate and tape is slackened. There is no damage to the video heads and the tape, but the VCR is not ready for immediate recording or playback.

**Standby On mode**

One of two conditions in the stop mode. The drum is rotating and the tape is wrapped round the drum. The VCR is ready for recording or playback, so a still picture can be obtained.

**Subcarrier**

A sine wave imposed on the luminance portion of a video signal and modulated to carry color information. Its amplitude represents color saturation and its phase, hue.

**Superimpose**

To put a set of characters onto a picture so that both can be seen at the same time.

**S-video**

A signal format in which Y (luminance) and C (chrominance) signals are separated to reduce interference between them so that noiseless images are reproduced.

**Sync signal**

A reference signal consisting of vertical and horizontal sync signals used for synchronizing the scanning patterns of the video camera and the monitor.

# Glossary

---

## **TBC**

Abbreviation of Time Base Corrector. Electronic circuits to electrically stabilize the playback signals by removing color variation and roll in the playback picture caused by irregularity in drum rotation and tape movement. Time base correction reduces deterioration of picture quality when transmitting or copying playback signals.

## **Threading**

See “Loading”.

## **Time code**

Signals recorded on the tape to supply information on tape position such as the hour, minute, second and frame, to assist in setting edit points or searching for particular scenes.

## **User bits**

Sections of time code information consisting of a total of 32 bits that can be used for recording information such as date, tape ID number, program ID number, etc.

## A

A MODE CHANGE (menu) .....	43
A/B roll editing system .....	59
A1 EDIT CH (menu) .....	43
A2 EDIT CH (menu) .....	43
AC IN connector .....	14
Accessories .....	7
AFTER CUE-UP (menu) .....	43
ALARM (menu) .....	45
Alarm messages .....	71
Analog audio signal input/output section .....	18
Analog interfaces .....	6, 15, 18
Analog recording .....	65
Analog video input/output section .....	15
Arrow (↔⇄⇅⇆) buttons .....	13
AUDIO CH1, 1/2 indicators .....	10
AUDIO CH-1, CH-1/2 button .....	10
AUDIO CH-2, 3/4 indicators .....	10
AUDIO CH-2, CH-3/4 button .....	10
AUDIO CONTROL (menu) .....	49
AUDIO IN 600 Ω ON/OFF Switches ...	18
AUDIO IN -6 dBm/0 dBm/+4 dBm Switches .....	18
AUDIO IN CH-1 to CH-4 connectors ...	18
AUDIO INPUT LEVEL control knobs ...	9
Audio input, selecting .....	20
Audio level meter .....	9
AUDIO MODE display .....	9
Audio mode indicators .....	9
Audio monitor system .....	60
AUDIO MUTE (menu) .....	47
AUDIO OUT CH-1 to CH-4 connectors .....	18
Audio problems .....	70
AUDIO REC SELECT button .....	9
Audio recording mode, selecting .....	21
AUTO EE SELECT (menu) .....	42
AUTO FUNCTION (menu) .....	50
Auto mode (AUTO FUNCTION) execution menu .....	50
AUTO REW (menu) .....	42

## B

BRIGHTNESS (menu) .....	45
B-Y signal input .....	16
B-Y signal output .....	16

## C

Care .....	77
Cassette compartment .....	8
Cassette memory indicator .....	11
Cassette memory .....	11, 22

Cassettes .....	21
inserting .....	25
notes on use .....	23
preventing accidental erasure .....	27
REC/SAVE switch .....	22, 27
tape slack .....	27
CHARA. DISPLAY (menu) .....	43
CHARA. POSITION (menu) .....	43
CHARA. TYPE (menu) .....	44
Cleaning, video heads .....	70
ClipLink function .....	6, 57
ClipLink indicator .....	11
CNT value, resetting .....	32
Color difference signal inputs .....	16
Color difference signal outputs .....	16
COMPONENT VIDEO Y, R-Y, B-Y/RGB IN connectors .....	15
COMPONENT VIDEO Y, R-Y, B-Y/RGB OUT connectors ...	15
Composite video input .....	15
Composite video output .....	15
Condensation .....	69
Connections and settings .....	57
A/B roll editing system .....	61
analog recording .....	65
audio monitor system .....	60
control signals .....	59
cut editing system .....	58
digital non-linear editing system .....	57
QSDI dubbing .....	64
reference video signal .....	59, 60
video monitor .....	59
video signals .....	59
CONTROL S connector .....	8
Control signals .....	59
COUNTER indicator .....	11
COUNTER SELECT button .....	11
Cut editing system .....	58

## D

DF MODE (menu) .....	45
DIGITAL AUDIO (AES/EBU) INPUT connectors .....	16
DIGITAL AUDIO (AES/EBU) OUTPUT connectors .....	16
Digital hours meter display menu ...	41, 69
Digital hours meter .....	41, 69
DIGITAL INPUT (menu) .....	47
Digital interfaces .....	6, 16
Digital non-linear editing system .....	57
Digital signal input/output section .....	16
Digital slow mode search .....	37
DISPLAY CONTROL (menu) .....	44

DISPLAY INFO (menu) .....	44
Drop frame mode .....	31
DSBK-120/120P .....	7, 17
DSBK-130/130P .....	7
DV format .....	5, 22
DVCAM format .....	5, 22

## E

Editing control unit, setting .....	63
Editing points, determining .....	37
Editing problems .....	72
Editing systems A/B roll editing system .....	59
cut editing system .....	58
digital non-linear editing system .....	57
EditStation .....	57
EE mode .....	9
EJECT button .....	12
Error messages .....	71
ES-7 .....	57
External synchronization, time code .....	34

## F, G

F FWD button .....	12
FREE RUN .....	34
FROM STILL (menu) .....	46
FROM STOP (menu) .....	46
Front panel .....	8

## H

Head cleaning .....	70
HEADPHONES connector .....	8
HEADPHONES control knob .....	8
High-speed search .....	37
High-speed transfer .....	6

## I

INPUT MODE display .....	9
Input problems .....	71
INPUT SELECT buttons .....	9
Input setting section .....	9
Interfaces .....	6
Internal time code generator/ reader .....	6, 31, 33, 34
advancement .....	34
using .....	33

## J, K

Jog audio, search .....	37
Jog .....	37

- L**
- LOCAL ENABLE (menu) ..... 42
  - Luminance signal input ..... 16
  - Luminance signal output ..... 16
- M**
- Maintenance ..... 69
  - MAX SRCH SPEED (menu) ..... 42
  - Menu ..... 41
    - basic items ..... 41, 51
    - changing menu settings ..... 51
    - contents ..... 42
    - digital hours meter display menu .... 41
    - enhanced items ..... 41, 53
    - operation example ..... 52
    - organization ..... 41
    - returning menu settings to the factory defaults ..... 54
    - setup menu ..... 41
  - MENU button ..... 13
  - Menu control panel ..... 13
  - MENU DISPLAY (menu) ..... 44
  - MENU GRADE (menu) ..... 47
  - 6 dBm/0 dBm/+4 dBm switches ..... 18
  - MONITOR AUDIO connector ..... 18
  - Monitor problems ..... 72
  - MONITOR SELECT switches ..... 13
- N**
- Non-drop frame mode ..... 31
  - Non-linear editing ..... 5
  - NOT EDITABLE indicator ..... 11, 26
  - Notes on use ..... 77
- O**
- Operation mode indications ..... 31
  - OPERATIONAL FUNCTION (menu) ..... 42
  - Optional accessories ..... 7
  - OVER DISP HOLD (menu) ..... 45
  - OVER indicator ..... 9
- P**
- PCM digital audio ..... 5
  - PEAK HOLD (menu) ..... 44
  - Picture search ..... 37
  - PLAY button ..... 12
  - PLAY START (menu) ..... 43
  - Playback compatibility ..... 5
  - Playback ..... 28
    - procedure ..... 29
    - settings ..... 28
  - POWER switch ..... 8
  - PREROLL TIME (menu) ..... 43
- Q**
- QSDI AUDIO MON (menu) ..... 43
  - QSDI button ..... 10
  - QSDI dubbing ..... 38
  - QSDI DUBBING (menu) ..... 50
  - QSDI indicator ..... 10
  - QSDI INPUT connector ..... 16
  - QSDI interface ..... 57
  - QSDI OUTPUT connector ..... 16
- R**
- Rack mounting ..... 7
  - Rear panel ..... 14
  - REC button ..... 12
  - REC INHIBIT indicator ..... 11, 25
  - REC POINT MUTE (menu) ..... 47
  - REC RUN ..... 34
  - Recording ..... 19
    - procedure ..... 24
    - settings ..... 19
  - REF LEVEL (menu) ..... 47
  - REF. VIDEO IN 75 Ω termination switch ..... 15
  - REF. VIDEO IN connectors ..... 15
  - REF. VIDEO OUT connector ..... 15
  - Reference video signal ..... 59, 60
  - Regular checks ..... 69
  - REMOTE connector ..... 14
  - REMOTE/LOCAL switch ..... 8
  - RESET (NO) button ..... 13
  - REW button ..... 12
  - RMM-130 ..... 7
  - RUN MODE (menu) ..... 45
  - R-Y signal input ..... 16
  - R-Y signal output ..... 16
- S**
- S VIDEO IN connector ..... 15
  - S VIDEO OUT connector ..... 15
  - SC PHASE control ..... 13
  - SDI INPUT connectors ..... 17
  - SDI OUTPUT connectors ..... 17
  - SDI signal input/output section ..... 17
  - Search ..... 37
  - SET (YES) button ..... 13
  - Settings ..... 51
    - menu settings ..... 51
    - See also "Connections and settings".*
  - SETUP ADD (menu) ..... 47
  - Setup menu ..... 41
  - SETUP REMOVE (menu) ..... 47
  - 75Ω termination switch ..... 15
  - Shipping ..... 77
  - Shuttle ..... 37
  - SIRCS ..... 6
    - 600Ω ON/OFF switches ..... 18
  - Specifications ..... 78
  - STILL MODE (menu) ..... 47
  - Still picture ..... 37
  - Still search ..... 37
  - STOP button ..... 12
  - Storage ..... 77
  - SUB STATUS (menu) ..... 44
  - Subcarrier phase, adjusting ..... 66
  - Superimposition ..... 15, 31, 55
  - Supplementary status information ..... 55
  - SYNC PHASE control ..... 13
  - Sync phase, adjusting ..... 66
- T**
- Tape
    - preventing accidental erasure ..... 27
    - problems ..... 71
    - slack ..... 27
    - See also "Cassettes".*
  - Tape end alarm indicator ..... 11
  - TAPE PROTECTION (menu) ..... 46
  - Tape transport control buttons ..... 12
  - TBC REMOTE connector ..... 14
  - TBC ..... 7, 14
  - TC EE OUT MODE (menu) ..... 46, 48
  - TC indicator ..... 11
  - TC INSERT (menu) ..... 50
  - TC insert function ..... 35
  - TC MODE (menu) ..... 45
  - TC PRESET button ..... 13
  - Time base corrector ..... 7
  - TIME CODE (menu) ..... 45
  - Time code generator ..... 6
  - TIME CODE IN connector ..... 15
  - TIME CODE OUT connector ..... 15
  - Time code reader ..... 6
  - Time code ..... 31
    - initial value, setting ..... 33
    - rerecording ..... 35
    - synchronizing ..... 33, 34
  - Time counter display ..... 11
  - Time data problems ..... 71

Time data type indicators .....	11
Time data problems .....	71
Time data type indicators .....	11
Time data .....	71
displaying .....	31, 32
problems .....	71
setting .....	31
Track pitch .....	5
Troubleshooting .....	71

## U

UB BINARY GP. (menu) .....	45
U-BIT indicator .....	11
User bit data, setting .....	33

## V, W, X

VIDEO button .....	10
VIDEO CONTROL (menu) .....	47
VIDEO IN 75 $\Omega$ termination switch .....	15
VIDEO IN connectors .....	15
VIDEO indicators .....	10
Video input, selecting .....	20
Video monitor .....	64
VIDEO OUT 1 connector .....	15
VIDEO OUT 2 (SUPER) connector .....	15
Video signals .....	63

## Y, Z

Y signal input .....	16
Y signal output .....	16







