

SONY

MINIATURE
MULTIPURPOSE
CAMERA

COLOR VIDEO CAMERA MODULE

XC-333/333P XC-777A/777AP XC-999/999P

Component/OEM



OUTLINE

The XC-999/XC-777A is an ultra-compact integrated camera module that has been developed for multimedia utilizing the latest surface mount technology. The XC-999/XC-777A is designed so that a video output signal can be obtained by only providing a power supply of 12 Vdc. It cannot only be easily installed in a limited space, but also is very suitable for outdoor use. The XC-333 is an ultra-compact remote head color camera that is widely used in the industrial field. The subminiature CHU block can be easily installed in limited spaces, the square head being precisely manufactured to ensure accurate alignment of the CCD. The XC-333 is also a highly functional DSP camera that can be controlled by RS-232C. The RGB signals can be adjusted separately and the AE mode can cope with a wide range of illumination. These three models use a unique NF mount lens system which can be converted into a flexible C mount lens.

MAJOR FEATURES

◁Outside image▷

XC-999
-999P



XC-777A
-777AP



XC-333
-333P



12 10 8 6 4 2 0 (cm)

- High resolution
Horizontal resolution
470TVlines/460TV lines
768(H)x494(V)/752(H)x582(V)pixels
- Electronic shutter function
- High sensitivity and high S/N ratio
- NF lens mount
(Can be converted into a C mount)

FEATURES OF EACH MODEL

- XC-999/999P
 - 1/2" IT Hyper HAD CCD mounted
 - Ultra-compact and lightweight
 - Can be used for various applications without CCU
 - CCD iris function
 - VBS and Y/C outputs
 - RGB output(with CMA-999)
 - External synchronization
- XC-777A/777AP
 - 1/3" IT Hyper HAD CCD mounted
 - Ultra-compact and lightweight
 - High vibration-resistant design
 - Can be used for various applications without CCU
 - VBS and Y/C outputs
- XC-333/333P
 - 1/4" IT Hyper HAD CCD mounted
 - Subminiature square remote head
 - Setting of each mode using on-screen menu
 - RGB can be changed independently
 - 3x Electronic zoom
 - AE function
 - Negative/positive conversion function
 - RS-232C control
 - External synchronization

XC-333/333P



MECHANICAL FEATURES

- The subminiature square CHU that enable easy installation in limited space.
- Cable separation: Automatically recognizes 2m, 5m, and 10m cables and displays the optimum picture quality.

FUNCTIONAL FEATURES

- Color reproducibility: The color matrix can be adjusted by DSP.
- Gamma variable: Gamma characteristics (curves) can be selected.
- AE control: The optimum sensitivity can be obtained by interlocking of an AGC and CCD iris.
- RS-232C: The same functions as the buttons on the front panel of a CCU can be set and controlled using a personal computer.

PRODUCT COMPOSITION

● Model Name	XC-333(NTSC)
CHU+CCU	XC-333P(PAL)

● CHU-CCU Connecting Exclusive Cable(Optional)



○ CCXC-T20P02
Cable length : 2m



○ CCXC-T20P05
Cable length : 5m



○ CCXC-T20P10
Cable length : 10m

The CHU and CCU blocks are the same in serial No.
After purchase, connect the CHU and CCU blocks with the same serial No. during use.

(- For different serial Nos., dispersion may occur in the fixed white balance at a color temperature of 3200K and 5600K.)

(- During trouble, return the CHU and CCU blocks with the same serial No. for repair.)

CONNECTIONS & ACCESSORIES

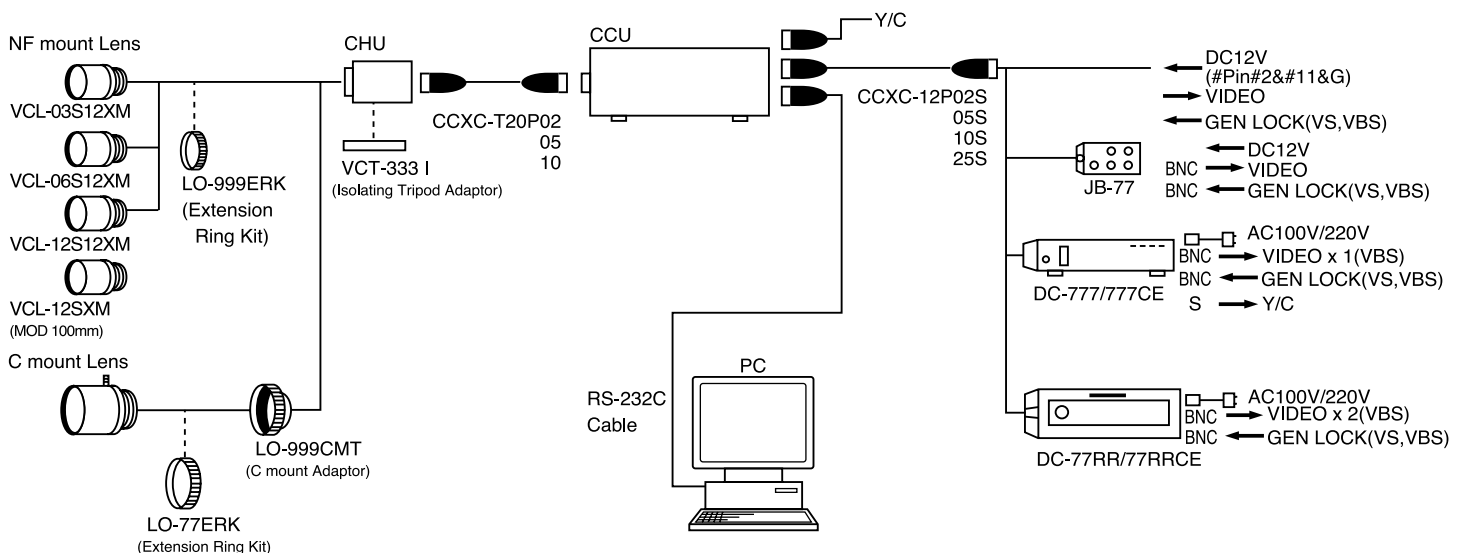

DIMENSIONS

● Camera Head Unit(CHU)

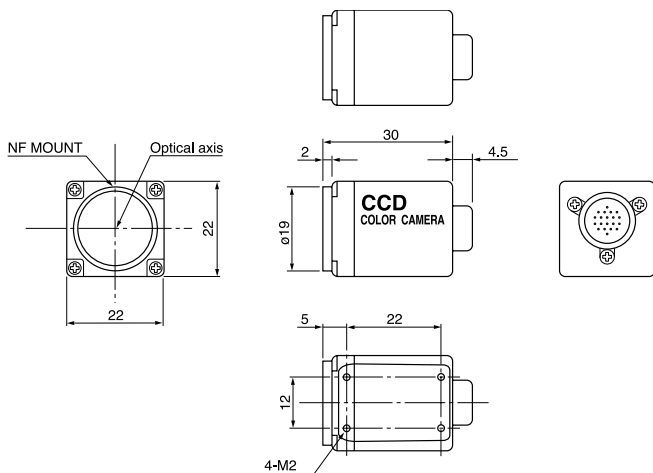

● Camera Control Unit(CCU)

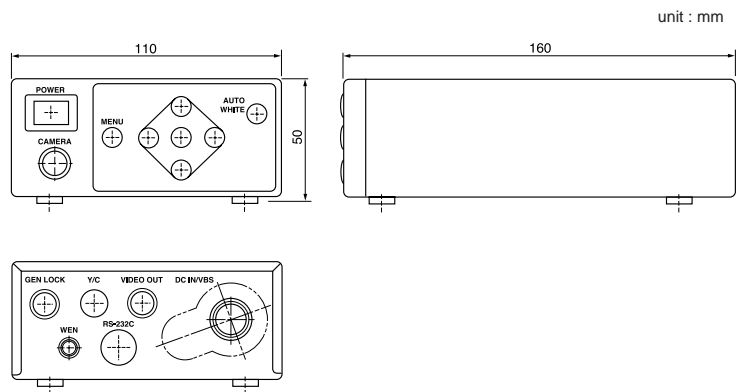

LOCATION & FUNCTION OF PARTS

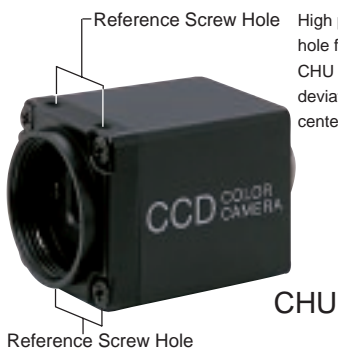

Reference Screw Hole
High precision screw hole for mounting CHU which keeps the deviation of the optical center minimum.

CHU

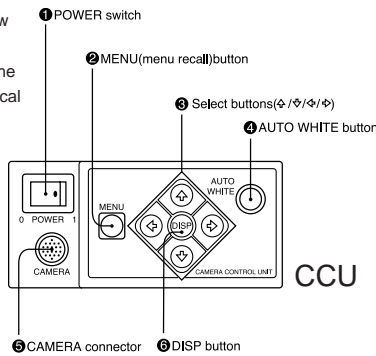

CCU

Front Panel(CCU)

- POWER switch
- MENU(menu recall) button : Pressing this button brings up the operational settings menu on the monitor connected to the camera. Press again to hide the menu.
- Select buttons : Press to change the position where the display blinks. Press to move to the desired setting position.
- AUTO WHITE(automatic white balance adjustment)button : When the menu is not displayed, the automatic white balance adjustment function activates if you press the button for more than one second.
- CAMERA connector : Connect a dedicated cable to CCU.(CCXC-T20P02/05/10)
- DISP button : When the menu is not displayed, press to select A or B settings stored into the camera.(A → B → LIVE → A → B...)

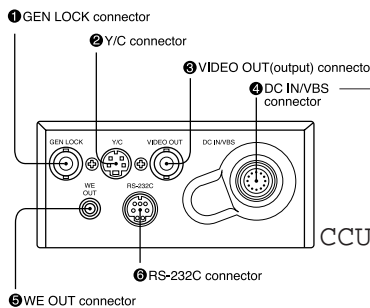

CCU

12Pin connector

Pin NO.	SIGNAL	SPECIFICATION
1	UNREG(G)	
2	UNREG(+)	+12V
3	VBS(G)	
4	VBS(+)/Y	1V p-p
5	---	
6	---	
7	GENLOCK(x)	1V p-p(VBS,VS)
8	---	
9	C(chroma)	0.3V p-p
10	UNREG(G)	
11	UNREG(+)	+12V
12	GENLOCK(G)	

Rear Panel(CCU)

- GEN LOCK(reference sync signal input)connector : Synchronization(including a burst signal)is established by inputting a VBS signal from the outside.
- Y/C connector : The camera output signal is separated into Y(luminance)and C (chroma)signal and can be extracted as a high-picture quality signal including no cross color.
- VIDEO OUT(output)connector : VBS output from a camera
- DC IN/VBS connecto : Connect to a camera adaptor.
- WE OUT connector : For long-time exposure. Effective for the interface with a video capture board
- RS-232C connector : Can be controlled by connecting a personal computer.

MENU SETTING ITEM

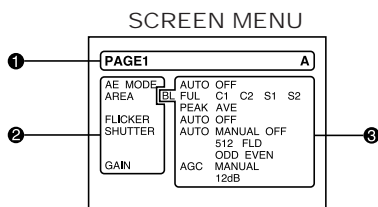

- Menu page : Displays the currently selected menu page.
- Setting items : The items which you can select on each menu page are displayed.
- Set values : Indicates the currently set value.

The video information shot using a camera can be changed by button operation while viewing the menu displayed on the monitor screen. The menu consists of five pages (PAGE 1 to PAGE 5). The menu is set using the menu operation button on the CCU side. For the external control using RS-232C, consult your local Sony office.

PAGE 1

Item	Contents of setting
AE MODE	Turns the automatic exposure on or off.
AREA	Sets the exposure area.
FLICKER SHUTTER	Cancels flickering of fluorescent light.
SHUTTER	Sets the electronic shutter.
GAIN	Adjusts video gain.



PAGE 2

Item	Contents of setting
W.B.	Selects the white balance settings.
PEDESTAL	Sets the pedestal level of the output signal.
GAMMA	Gamma compensation(on/off).
H ENH	Sets the horizontal enhancement.
V ENH	Sets the vertical enhancement.
ZOOM	Sets the zoom.



PAGE 3

Item	Contents of setting
BAR	Selects the position to display the color bar.
NEGA	Negative/positive display of the images.
OUTPUT	Selects video output signal for the 12Pin connector.
BAUD RATE	Selects the baud rate.
SC PHASE ^{a)}	Adjusts the difference in phase of the subcarrier during external synchronization.
SC 0/180 ^{a)}	Adjusts the angle in phase of the subcarrier.
H.PHASE ^{a)}	Adjusts the difference in phase of the horizontal synchronization during external synchronization.

PAGE 5

Item	Contents of setting
SAVE	Stores the user preset value.
RESET	Returns to the factory-set value.



PAGE 4

Item	Contents of setting
COLOR	Adjustment of the hue of the screen.
MATRIX	
GAMMA	Selects either color or monochrome.



^{a)} Only displayed when an external video signal is input.

DIMENSIONS

	XC-333(NTSC)	XC-333P(PAL)
Pick up device	1/4-inch IT Hyper HAD CCD	
Color filter	Complementary color mosaic	
Effective picture elements	768(H) x 494(V)	752(H) x 582(V)
Lens mount	NF mount(Can be converted into a C mount)	
Synchronization	Internal/External(auto)	
Horizontal resolution	470TV lines	460TV lines
Minimum illumination	10 lx (F 1.2, AGC ON)	
Sensitivity	2000 lx F 5.6(3200K, 0dB)	
Video output signals	VBS, Y/C	
S/N ratio	46dB or more	44dB or more
Electronic shutter speed	CCD IRIS, Manual(1/100~1/40,000sec.)	
	Long exposure(adjustable range of 2 to 512 fields)	
White balance	AWE, ATW, 3200K, 5600K, Manual	
Gain control	AGC, Manual(0~12dB)1dB step	
Pedestal adjustment	Switchable	
Electronic zoom	1 x to 3 x	
Enhance setting	Horizontal/Vertical	
Color bar	High is selectable(3 types)	
Color matrix	R.G.B. adjustable	
Nega/posi	Switchable	
External sync input	VBS(VBS 1Vp-p or B.B 0.3Vp-p), VS	
External control	RS-232C	
Power requirements	DC10.5~15V(typical12V)	
Power consumptions	5W	
Operating temp./mois.	-5°C~+45°C/20%~80%(no condensation permissible)	
Strage temp./mois.	-20°C~+60°C/20%~80%(no condensation permissible)	
Dimensions	CHU	22(W) x 22(H) x 30(D)mm
	CCU	110(W) x 50(H) x 160(D)mm
Weight	CHU	40g
	CCU	665g
MTBF	29,800Hrs	
Regulations	UL1492, FCC Class A Digital Device, CE(EN50081-1, EN50082-1), AS4251.1	
Supplied accessories	Lens mount cap(1), Operating Instructions(1), Clamp filter(1)	

LONG EXPOSURE

Long exposure allows high sensitive image capture by long time integration using electronic shutter.

WE pulse is output from "WE OUT connector" on the rear side of CCU. WE pulse is useful to know the timing when capturing image using equipment such as memory.

Effective period of outputting to WE pulse is 2FLD~512FLD.

Timing chart in long exposure mode of the electronic shutter

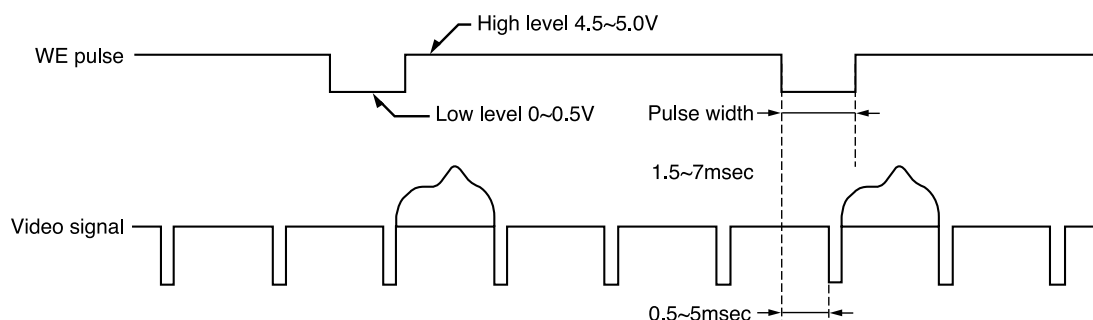

1/2" CCD COLOR CAMERA MODULE **XC-999/999P**

XC-999/999P

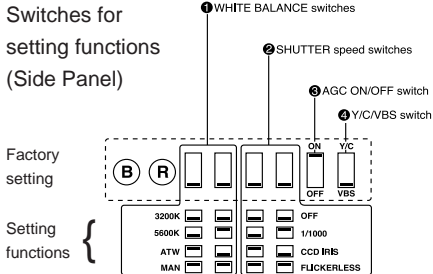

RGB ADAPTOR

CMA-999/999P



SPECIFICATIONS

	XC-999(NTSC)	XC-999P(PAL)
Pick up devices	1/2-inch IT Hyper HAD CCD	
Color filter	Complementary color mosaic	
Effective picture elements	768(H) x 494(V)	752(H) x 582(V)
Lens mount	NF mount(Can be converted into a C mount)	
Synchronization	Internal/External(auto)	
External sync system	HD/VD(2~4Vp-p), VS	
External sync frequency	±50ppm	
Horizontal resolution	470TV lines	460TV lines
Minimum illumination	4.5 lx (F 1.2, AGC)	
Sensitivity	2000 lx F 5.6(3200K, 0dB)	
Video output signals	VBS, Y/C selected with the switch	
S/N ratio	48dB or more	46dB or more
Electronic shutter speed	1/1,000sec., CCD IRIS, FL	
White balance	ATW, 3200K, 5600K, Manual(R.B)	
Gain control	AGC, 0dB	
Power requirements	DC10.5~15V(typical12V)	
Power consumptions	3.5W	
Dimensions	22(W) x 22(H) x 120(D)mm(excluding projecting parts)	
Weight	about 99g	
MTBF	34,800Hrs	
Regulations	UL1409, FCC Class A Digital Device, CE(EN50081-1+EN50082-1)	
Supplied accessories	Lens mount cap(1), Tripod adaptor(1 set) Screwdriver(1), Label(1), Operating Instructions(1)	

	CMA-999/999P
Video output signals	RGB, Y/C, VBS
External sync signals	VBS, VS, HD/VD
Power requirements	DC10.5~15V(typical12V)
Shutter control	CCD IRIS, Manual(1/60(1/50)~about 1/4,000sec.)
Power consumptions	4.5W
Dimensions	133.5(W) x 30(H) x 69(D)mm(excluding projecting parts)
Weight	about 290g

CONNECTIONS

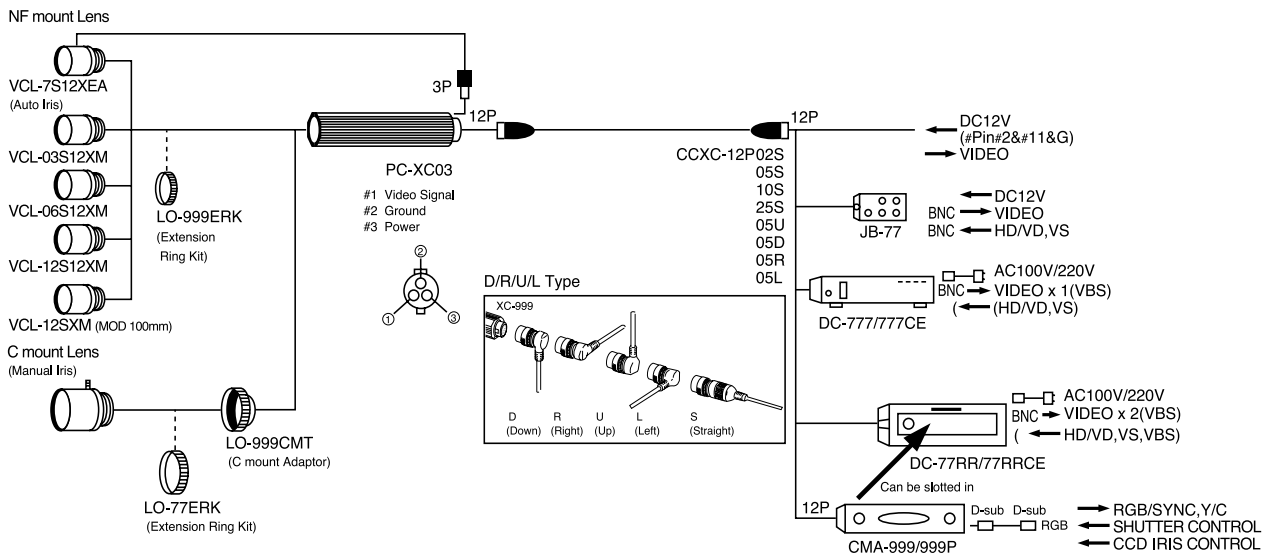

DIMENSIONS

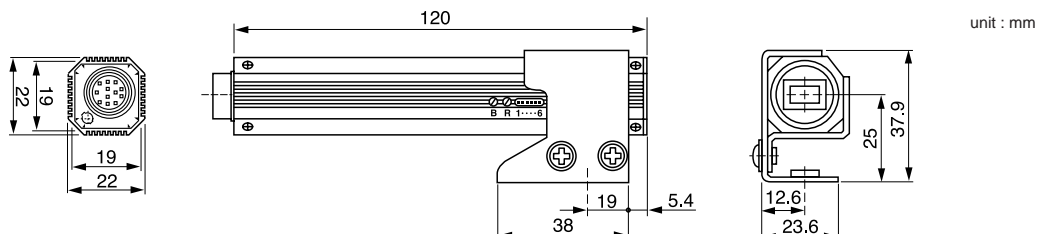

1/3" CCD COLOR CAMERA MODULE XC-777A/777AP

XC-777A/777AP

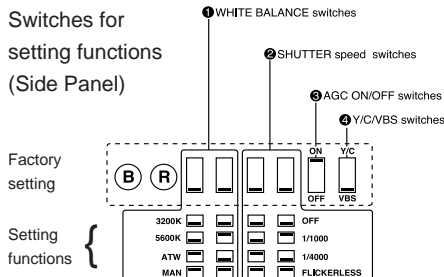

CAMERA ADAPTOR DC-777/777CE



SPECIFICATIONS

	XC-777A(NTSC)	XC-777AP(PAL)
Pick up devices	1/3-inch IT Hyper HAD CCD	
Color filter	Complementary color mosaic	
Effective picture elements	768(H) x 494(V)	752(H) x 582(V)
Lens mount	NF mount(Can be converted into a C mount)	
Horizontal resolution	470TV lines	460TV lines
Minimum illumination	4.5 lx (F 1.2, AGC)	
Sensitivity	2000 lx F 5.6(3200K, 0dB)	
Video output signals	VBS, Y/C selected with the switch	
S/N ratio	48dB or more	46dB or more
Electronic shutter speed	1/1,000, 1/4,000sec., FL	
White balance	ATW, 3200K, 5600K, Manual(R.B)	
Gain control	AGC, 0dB	
Power requirements	DC10.5~15V(typical12V)	
Power consumptions	2.3W	
Dimensions	22(W) x 22(H) x 89(D)mm(excluding projecting parts)	
Weight	about 75g	
MTBF	38,200Hrs	
Regulations	UL1409, FCC Class A Digital Device, CE(EN50081-1+EN50082-1), AS4251.1	
Supplied accessories	Lens mount cap(1), Tripod adaptor(1 set) Screwdriver(1), Label(1), Operating Instructions(1)	

	DC-777/777CE
Power requirements	AC100V/220V, 50/60Hz
DC output	DC12V, 1.3A
Input/Output connectors	HD IN, VD IN(XC-777A/777AP is impossible)
	VIDEO OUT(VBS)
	CAMERA connector(12pin connector)
Dimensions	210(W) x 44(H) x 200(D)mm
Weight	1.1kg

DC-777/777CE is the camera adaptor designed for XC-777A/777AP.
It can also be used with most of XC cameras as a camera adaptor.

CONNECTIONS

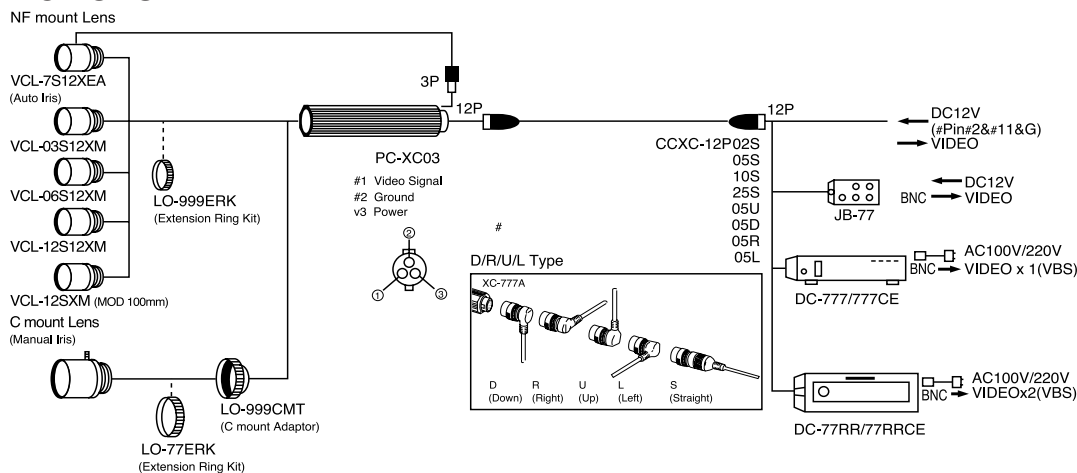

DIMENSIONS

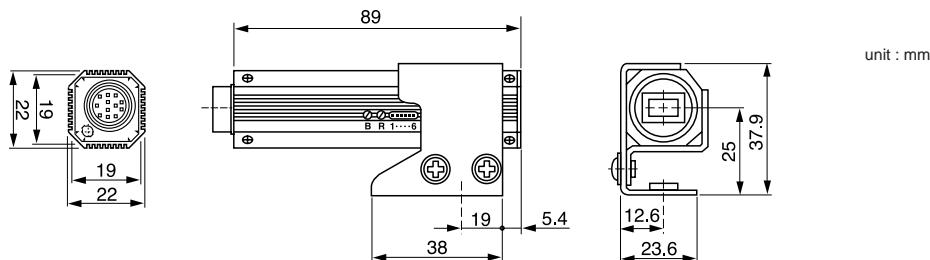

● Sony Electronics Inc. ISP(USA)

Itasca Office
San Jose Office
Park Ridge Office

● Sony of Canada Ltd.(CANADA)

● Sony Broadcast & Professional Europe

HQ
Germany
France
UK
Nordic
Italy

1200 N. Arlington Heights Rd, MD-1118 Itasca, IL 60143-1291
3300 Zanker Rd, MS-SJ2B1 San Jose, CA 95134-1901
1 Sony Drive Park Ridge, NJ 07645
411 Gordon Baker Road, Willowdale, Ontario M2H 2S6

15, rue Floreal 75831 Paris Cedex 17, France
Hugo-Eckener-Str. 20, 50829 Koln
15, rue Floreal 75831 Paris Cedex 17
The Heights, Brooklands, Weybridge, Surrey KT13 0XW
Per Albin Hanssons vag 20 S-214 32 Malmo Sweden
Via Galileo Galilei 40 I-20092 Cinisello Balsamo, Milano

(TEL:+1-630-773-7604) (FAX:+1-630-773-7605)
(TEL:+1-408-955-5623) (FAX:+1-408-955-5630)
(TEL:+1-201-358-4173) (FAX:+1-201-358-4401)
(TEL:+1-416-499-1414) (FAX:+1-416-497-1774)

(TEL:+33-1-40-87-35-11) (FAX:+33-1-40-87-35-17)
(TEL:+49-221-5966-322) (FAX:+49-221-5966-491)
(TEL:+33-1-49-45-41-62) (FAX:+33-1-47-31-13-57)
(TEL:+44-990-331122) (FAX:+44-1932-817011)
(TEL:+46-40-190-800) (FAX:+46-40-190-450)
(TEL:+39-2-618-38-431) (FAX:+39-2-618-38-402)
(FAX:+81-462-27-2347)